

—
The PSE has been designed to meet the most common requirements from the water segment and is specialized on pump operation. It combines the requested protections with a very compact design and built-in bypass. Remote operation with external keypad or over fieldbus is available as an option.

PSE

The efficient range

42	Introduction
44	Coordination examples
45	Ordering details
46	Accessories
48	Technical data
50	Dimensions
51	Circuit diagrams

PSE - The efficient range

Introduction



Technical specifications

- Rated operational current: 18...370 A
- Operational voltage: 208...600 V AC
- Wide rated control supply voltage: 100...250 V AC, 50/60 Hz

Features

- Voltage ramp and torque control for both start and stop
- Two-phase controlled
- Current limit
- Kick-start
- Built-in bypass for energy saving and easy installation
- Illuminated display that uses symbols to become language neutral
- External keypad rated IP66 (Type 1, 4X,12) as an option
- Analog output for display of motor current

Protections

- Electronic overload protection
- Underload protection
- Locked rotor protection

Communication

- Built-in Modbus RTU
- Fieldbus communication with fieldbus plug adapter and fieldbus plug



Basic motor protection and current limit

The PSE includes the most important protections for handling different load situations that can happen to pumps e.g. overload and underload. The current limit gives you more control of the motor during start and allows you to start your motor in weaker networks.



Saving time and money with built-in bypass and compact design

On the PSE, the bypass is built in and verified by ABB, saving you time during installation and space in your panel. The keypad is language neutral and illuminated for easy set-up and operation in field. The compact design makes installation fast and easy.



Torque control for elimination of water hammering in pumps

Torque control is the most efficient way to stop a full speed pump. The PSE has a special torque stop ramp that is designed together with a pump manufacturer to eliminate water hammering in an optimal way.



Screw mounting PSE is fast easy to install by using screw mounting.

Digital input for start, stop and reset PSE is controlled through digital inputs using the internal 24 V DC source. This allows easy control with e.g. push buttons or relays.

Output signal relays for run, top of ramp and event Three output signal relays for indicating that the motor is running, that the softstarter is in top of ramp and if any event has happened. The relays can be used e.g. with pilot lights or to control a line contactor.

Coated circuit boards protecting from dust, moist and corrosive atmosphere.

Torque control function the absolutely best possible stop of pumps without water hammering and pressure surges.

NEW Modbus-RTU fieldbus communication for monitoring and control. Support for all major communication protocols.

PSE display

Illuminated and language-neutral display with icons The display on PSE uses icons for fast and easy set-up of parameters. Each icon indicates a different parameter to set and makes navigation and setting of parameters easy.

LED indicators

- Green ready LED
Flashing - Control supply
Steady - Main power available
- Green run LED
Flashing - Ramping up/down
Steady - TOR
- Yellow protection LED
- Red fault LED

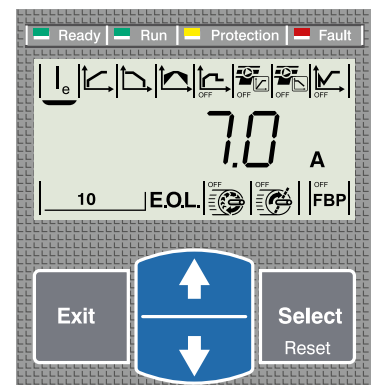

PSE - The efficient range

Coordination examples



Normal start In-line connected

Softstarter	PSE18	PSE25	PSE30	PSE37	PSE45	PSE60	PSE72	PSE85	PSE105
IEC kW (400V)	7.5	11	15	18.5	22	30	37	45	55
IEC max A	18	25	30	37	45	60	72	85	106
UL HP (440-480 V)	10	15	20	25	30	40	50	60	75
UL max FLA	18	25	28	34	42	60	68	80	104
Using MCCB only, type 1 coordination will be achieved ¹⁾	MCCB (400 V, 40 °C)								
MCCB (35 kA)	XT2N160	XT2N160	XT2N160	XT2N160	XT2N160	XT2N160	XT2N160	XT2N160	XT3N250
MCCB (50 kA)	XT2S160	XT2S160	XT2S160	XT2S160	XT2S160	XT2S160	XT2S160	XT2S160	XT3S250
To achieve type 2 coordination, semi-conductor fuses must be used ¹⁾	Fuse protection (85 kA), Semiconductor fuses, Bussmann								
	170M1563	170M1564	170M1566	170M1567	170M1568	170M1569	170M1571	170M1572	170M3819
Suitable switch fuse for recommended semi-conductor fuses ¹⁾	Switch fuse								
	OS32GD	OS32GD	OS32GD	OS63GD	OS63GD	OS63GD	OS125GD	OS125GD	OS250D
The line contactor is not required for the softstarter itself but often used to open if OL trips ¹⁾	Line contactor								
	AF26	AF26	AF30	AF38	AF52	AF65	AF80	AF96	AF116

Softstarter	PSE142	PSE170	PSE210	PSE250	PSE300	PSE370
(400 V) kW	75	90	110	132	160	200
IEC, max. A	143	171	210	250	300	370
(440-480 V) hp	100	125	150	200	250	300
UL, max. FLA	130	169	192	248	302	361
Using MCCB only, type 1 coordination will be achieved ¹⁾	MCCB (400 V, 40 °C)					
MCCB (35 kA)	XT3N250	XT3N250	XT4N320	XT5N400	XT5N400	XT5N630
MCCB (50 kA)	XT3S250	XT3S250	XT4S320	XT5S400	XT5S400	XT5S630
To achieve type 2 coordination, semi-conductor fuses must be used ¹⁾	Fuse protection (85kA), Semiconductor fuses, Bussmann					
	170M5809	170M5810	170M5812	170M5813	170M6812	170M6813
Suitable switch fuse for recommended semi-conductor fuses ¹⁾	Switch fuse					
	OS400D	OS400D	OS400D	OS400D	OS630D	OS630D
The line contactor is not required for the softstarter itself but often used to open if OL trips ¹⁾	Line contactor					
	AF146	AF190	AF265	AF265	AF305	AF370

¹⁾ These are an example of coordination. For more examples see: <https://applications.it.abb.com/SOC/Page/Selection.aspx>

PSE - The efficient range

Ordering details



PSE18 ... PSE105



PSE142 ... PSE170



PSE210 ... PSE370

NOTE

PSE range updates (2018)

- Built in Modbus-RTU communication protocol added
- Increased firmware & hardware stability and reliability
- Improved package and inlay

PSE frame C updates (2018)

PSE210..PSE370 redesigned with more compact size and have new order codes replacing existing PSE Frame C that will be phased out. Terminal extension kit available as accessory for retro-fit.

Normal starts, class 10, in-line Rated operational voltage U_e , 208-600 V, Rated control supply voltage U_s , 100-250 V AC, 50/60 Hz

IEC Rated operational power			UL/CSA Rated operational power							FLA	Type	Order code	Net weight	
230 V	400 V	500 V	current	200/208 V	220/240 V	440/480 V	550/600 V	current	kg				lb	
P_e	P_e	P_e	I_e	P_e	P_e	P_e	P_e	FLA						
kW	kW	kW	A	hp	hp	hp	hp	A				kg	lb	
4	7.5	11	18	5	5	10	15	18	PSE18-600-70	1SFA897101R7000	2.5	5.5		
5.5	11	15	25	7.5	7.5	15	20	25	PSE25-600-70	1SFA897102R7000	2.5	5.5		
7.5	15	18.5	30	7.5	10	20	25	28	PSE30-600-70	1SFA897103R7000	2.5	5.5		
9	18.5	22	37	10	10	25	30	34	PSE37-600-70	1SFA897104R7000	2.5	5.5		
11	22	30	45	10	15	30	40	42	PSE45-600-70	1SFA897105R7000	2.5	5.5		
15	30	37	60	20	20	40	50	60	PSE60-600-70	1SFA897106R7000	2.5	5.5		
18.5	37	45	72	20	25	50	60	68	PSE72-600-70	1SFA897107R7000	2.5	5.5		
22	45	55	85	25	30	60	75	80	PSE85-600-70	1SFA897108R7000	2.6	5.7		
30	55	75	106	30	40	75	100	104	PSE105-600-70	1SFA897109R7000	2.9	6.3		
40	75	90	143	40	50	100	125	130	PSE142-600-70	1SFA897110R7000	4.4	9.7		
45	90	110	171	60	60	125	150	169	PSE170-600-70	1SFA897111R7000	4.4	9.7		
59	110	132	210	60	75	150	200	192	PSE210-600-70-1	1SFA897112R7001	8.5	18.7		
75	132	160	250	75	100	200	250	248	PSE250-600-70-1	1SFA897113R7001	10.6	23.3		
90	160	200	300	100	100	250	300	302	PSE300-600-70-1	1SFA897114R7001	10.6	23.3		
110	200	250	370	125	150	300	350	361	PSE370-600-70-1	1SFA897115R7001	10.6	23.3		

Heavy-duty starts, class 30, in-line Rated operational voltage U_e , 208...600 V, Rated control supply voltage U_s , 100...250 V AC, 50/60 Hz

IEC Rated operational power			UL/CSA Rated operational power							FLA	Type	Order code	Net weight	
230 V	400 V	500 V	current	200/208 V	220/240 V	440/480 V	550/600 V	current	kg				lb	
P_e	P_e	P_e	I_e	P_e	P_e	P_e	P_e	FLA						
kW	kW	kW	A	hp	hp	hp	hp	A				kg	lb	
3	5.5	7.5	12	3	3	7.5	10	11	PSE18-600-70	1SFA897101R7000	2.5	5.5		
4	7.5	11	18	5	5	10	15	18	PSE25-600-70	1SFA897102R7000	2.5	5.5		
5.5	11	15	25	7.5	7.5	15	20	25	PSE30-600-70	1SFA897103R7000	2.5	5.5		
7.5	15	18.5	30	7.5	10	20	25	28	PSE37-600-70	1SFA897104R7000	2.5	5.5		
9	18.5	22	37	10	10	25	30	34	PSE45-600-70	1SFA897105R7000	2.5	5.5		
11	22	30	45	10	15	30	40	42	PSE60-600-70	1SFA897106R7000	2.5	5.5		
15	30	37	60	20	20	40	50	60	PSE72-600-70	1SFA897107R7000	2.5	5.5		
18.5	37	45	72	20	25	50	60	68	PSE85-600-70	1SFA897108R7000	2.6	5.7		
22	45	55	85	25	30	60	75	80	PSE105-600-70	1SFA897109R7000	2.9	6.3		
30	55	75	106	30	40	75	100	104	PSE142-600-70	1SFA897110R7000	4.4	9.7		
40	75	90	143	40	50	100	125	130	PSE170-600-70	1SFA897111R7000	4.4	9.7		
45	90	110	171	60	60	125	150	169	PSE210-600-70-1	1SFA897112R7001	8.5	18.7		
59	110	132	210	60	75	150	200	192	PSE250-600-70-1	1SFA897113R7001	10.6	23.3		
75	132	160	250	75	100	200	250	248	PSE300-600-70-1	1SFA897114R7001	10.6	23.3		
90	160	200	300	100	100	250	300	302	PSE370-600-70-1	1SFA897115R7001	10.6	23.3		

PSE - The efficient range

Accessories



Cable connectors for CU cables

Cable connectors for Cu cables

Article	Wire range mm ²	Tightening torque max Nm	Type	Order code	Pkg qty	Net kg	lb
PSE142 ... PSE170	6...120	14	KIT FC Cu XT4 3pcs	1SDA066917R1	3	0.18	0.40
PSE142 ... PSE170	2 x (50...120)	16	LZ185-2C/120	1SFN074709R1000	3	0.10	0.22
PSE210 ... PSE370	16...300	25	T5 400 3pcs	1SDA055016R1	3	0.39	0.45



Cable connectors for CU & AL cables

Cable connectors for Al and Cu cables

Article	Wire range mm ²	Tightening torque max Nm	Type	Order code	Pkg qty	Net kg	lb
PSE142 ... PSE170	95...185	31	KIT FC CuAl T4 3pcs	1SDA054988R1	3	0.14	0.31
PSE210 ... PSE370	185...240	43	KIT FC CuAl T5 400 3pcs	1SDA055020R1	3	0.24	0.54

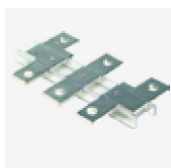

Terminal enlargements

Terminal enlargements

Article	Dimensions hole ø mm ²	bar mm ²	Type	Order code	Pkg qty	Net kg	lb
PSE18 ... PSE105	6.5	15 x 3	LW110	1SFN074307R1000	1	0.07	0.14
PSE142 ... PSE170	10.5	17.5 x 5	LW185	1SFN074707R1000	1	0.29	0.64
PSE210 ... PSE370	10.5	20 x 5	LW300	1SFN075107R1000	1	0.49	1.08



Terminal kit

Terminal kit

Article	Type	Order code	Pkg qty	Net kg	lb
PSE142...PSE170	PSLE-185	1SFA899221R1002	1	0.34	0.75
PSE210...370	PSLE-300	1SFA899221R1003	1	0.30	0.66



Terminal extension

Terminal extension

Article	Type	Order code	Pkg qty	Net kg	lb
PSE142 ... PSE170 8.5 17.5 x 5	LX205	1SFN074810R1000	1	0.25	0.55
PSE210 ... PSE370 10.5 20 x 5	LX370	1SFN075410R1000	1	0.35	0.77

PSE - The efficient range

Accessories



Terminal shrouds

Terminal shrouds

Article	Type	Order code	Pkg qty	Net kg	lb
PSE18... PSE105, Screw terminals	LT140-30L	1SFN124203R1000	2	0.07	0.15
PSE142... PSE170, short for use with cable clamps	LT185-AC	1SFN124701R1000	2	0.05	0.11
PSE142... PSE170, long for use with compression lugs	LT185-AL	1SFN124703R1000	2	0.22	0.49
PSE210... PSE370, short for use with cable clamps	LT300-AC	1SFN125101R1000	2	0.09	0.19
PSE210... PSE370, long for use with compression lugs	LT300-AL	1SFN125103R1000	2	0.28	0.62



External keypad

External keypad including a 3m cable

Article	Type	Order code	Pkg qty	Net kg	lb
PSE18 ... PSE370	PSEEK	1SFA897100R1001	1	0.13	0.29



USB cable

USB cable for Service Engineer Tool

Article	Type	Order code	Pkg qty	Net kg	lb
PSE18 ... PSE370	PSECA	1SFA897201R1001	1	0.10	0.22



Fieldbus plug adaptor

Fieldbus plug connection, cable included

Article	Type	Order code	Pkg qty	Net kg	lb
Fieldbus plug adaptor	PS-FBPA	1SFA896312R1002	1	0.15	0.33



Terminal extensions retrofit kit

Terminal extensions retrofit kit

Article	Type	Order code	Pkg qty	Net kg	lb
Terminal extensions retrofit kit	LXR370	1SFA899222R1003	1	0.45	0.99



Modbus adapter

Modbus adapter

Article	Type	Order code	Pkg qty	Net kg	lb
Modbus adapter	PS-MBIA	1SFA899300R1020	1	0.01	0.02

PSE - The efficient range

Technical data

Technical data	PSE18 ... PSE370
Rated insulation voltage U_i	600 V
Rated operational voltage U_e	208...600 V +10%/-15%
Rated control supply voltage U_s	100...250 V +10%/-15%, 50/60 Hz \pm 10 %
Rated control circuit voltage U_c	Internal 24 V DC
Starting capacity at I_e	4 x I_e for 10 sec.
Number of starts per hour	10 ¹⁾
Maximum Altitude	4000 m (13123 ft) ³⁾
Overload capability	
Overload class	10
Ambient temperature	
During operation	-25...+60 °C (-13...+140 F) ²⁾
During storage	-40...+70 °C (-40...+158 F)
Degree of protection	
Main circuit	IP00
Supply and control circuit	IP20
Main circuit	
Built-in bypass	Yes
Cooling system	fan cooled (thermostat controlled)
HMI for settings	
Display	4 7-segments and icons. Illuminated
Keypad	2 selection keys and 2 navigation keys
Main settings	
Setting current	Size dependent
Ramp time during start	1...30 sec
Ramp time during stop	0...30 sec
Initial/end voltage	30...70%
Current limit	1.5...7 x I_e
Torque control for start	Yes / No
Torque control for stop	Yes / No
Kick start	Off, 30...100%
Signal relays	
Number of signal relays	3
K2	Run signal
K3	TOR (bypass) signal
K1	Event signal
Rated operational voltage U_e	100-250 V AC/24 V DC ⁴⁾
Rated thermal current I_{th}	3 A
Rated operational current I_e at AC-15 ($U_e = 250$ V)	1.5 A
Vibration test	
According to IEC 60068-2-6:2007	

Technical data	PSE18 ... PSE370
Analog output	
Output signal reference	4...20 mA
Type of output signal	1 Amp
Scaling	Fixed at 1.2 x I_e
Control circuit	
Number of inputs	3 (start, stop, reset of faults)
Signal indication LED	
On / Ready	Green flashing / steady
Run / TOR	Green flashing / steady
Protection	Yellow
Fault	Red
Protections	
Electronic overload	Yes (Class 10A, 10, 20, 30)
Locked rotor protection	Yes
Underload protection	Yes
Fieldbus connection	
ABB Fieldbus plug	Yes (option)
NEW Built-in modbus	Yes
External keypad	
Display	LCD type
Ambient temperature	
During operation	-25...+60 °C (-13...+140 F)
During storage	-40...+70 °C (-40...+158 F)
Degree of protection	IP66

¹⁾ Valid for 50% on time and 50% off time. If other data is required, contact your local ABB office.

²⁾ Above 40 °C (104 F) up to max. 60 °C (140 F) reduce the rated current with 0.6% per °C (0.33% per F).

³⁾ When used at high altitudes, above 1000 meters (3281 ft) up to 4000 meters (13123 ft), de-rate the rated current using the following formula. [% of $I_e = 100 - \frac{x - 1000}{150}$] x = actual altitude of the softstarter in meters.

⁴⁾ A common voltage needs to be used for all 3 signal relays.

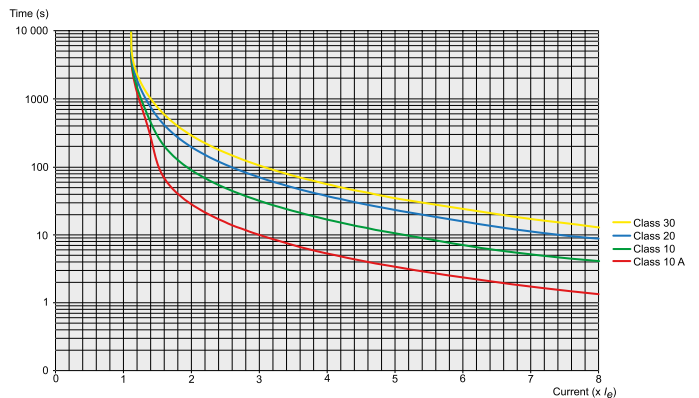

Tripping curves for the integrated electronic overload protection
PSE has an integrated electronic overload protection that can be set to four different tripping classes. Below you find a curve for each tripping class in cold state.

PSE - The efficient range

Technical data

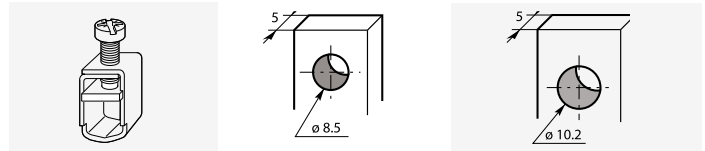

Main terminals

Article	PSE18... 105	PSE142... 170	PSE210... 370
Cu cable - Flexible 1 x mm²	2.5...70 mm ²	6...120 mm ²	16...300 mm ²
Clamp type	Included	1SDA066917R1	1SDA055016R1
Tightening torque	8 Nm	14 Nm	25 Nm
Cu cable - Flexible 2 x mm²	2.5...70 mm ²	50...120 mm ²	-
Clamp type	Included	1SFN074709R1000	-
Tightening torque	8 Nm	16 NM	-
Cu cable - Stranded 1 x mm²	2.5...70 mm ²	6...120 mm ²	16...300 mm ²
Clamp type	Included	1SDA066917R1	1SDA055016R1
Tightening torque	8 Nm	14 Nm	25 Nm
Cu cable - Stranded 2 x mm²	2.5...70 mm ²	50...120 mm ²	-
Clamp type	Included	1SFN074709R1000	-
Tightening torque	8 Nm	16 NM	-
Al cable - Stranded 1 x mm²	-	95...185 mm ²	185...240
Clamp type	-	1SDA054988R1	1SDA055020R1
Tightening torque	-	31 Nm	43 Nm
Lugs			
Width	22 mm (0.866 in)	24 mm (0.945 in)	30 mm (1.181 in)
Diameter>=	6.5 mm (0.256 in)	8.5 mm (0.335 in)	10.2 mm (0.402 in)
Tightening torque	9 Nm (80 in lb)	18 Nm (159 in lb)	28 Nm (248 in lb)
Connection capacity acc to UL/CSA 1 x AWG/kcmil	6...2/0	6...300 kcmil	4...400 kcmil
Clamp type	Included	ATK185	ATK300
Tightening torque	71 in lb	300 in lb	375 in lb
Connection capacity acc to UL/CSA 2 x AWG/kcmil	-	-	4...500 kcmil
Clamp type	-	-	ATK300/2
Tightening torque	-	-	375 in lb
Supply and control circuit			
Cu cable - Stranded 1 x mm ²	0.75...2.5 mm ² (19...14 AWG)		
Cu cable - Stranded 2 x mm ²	0.75...1.5 mm ² (19...16 AWG)		
Tightening torque	0.5 Nm (4.4 in lb)		

Fuse ratings and power losses

Softstarter	Current range	Max power loss at rated I _n	Max fuse rating - main circuit ¹⁾		Power requirements supply circuit	
	A	W	A	Type	Size	Holding (VA) / Pull-in (VA)
PSE18	5.4...18.0	0.2	40	170M1563	000	16/19.9
PSE25	7.5...25.0	0.4	50	170M1564	000	16/19.9
PSE30	9.0...30.0	0.5	80	170M1566	000	16/19.9
PSE37	11.1...37.0	0.8	100	170M1567	000	16/19.9
PSE45	13.5...45.0	1.2	125	170M1568	000	16/19.9
PSE60	18.0...60.0	2.2	160	170M1569	000	16/19.9
PSE72	21.6...72.0	3.1	250	170M1571	000	16/19.9
PSE85	25.5...85.0	4.3	315	170M1572	000	16/19.9
PSE105	31.8...106.0	6.6	400	170M3819	1*	16/19.9
PSE142	42.9...143.0	12.1	450	170M5809	2	16/31
PSE170	51.3...171.0	17.6	500	170M5810	2	16/31
PSE210	63.0...210.0	8.8	630	170M5812	2	21/244
PSE250	75.0...250.0	12.5	700	170M5813	2	21/244
PSE300	90.6...302.0	18.0	800	170M6812	3	21/244
PSE370	111.0...370.0	27.4	900	170M6813	3	21/244

¹⁾ For the supply circuit 6 A delayed, for MCB use C characteristics.

PSE - The efficient range

Dimensions

PSE18... 105

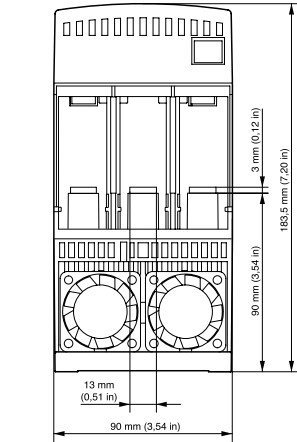

PSE142... 170

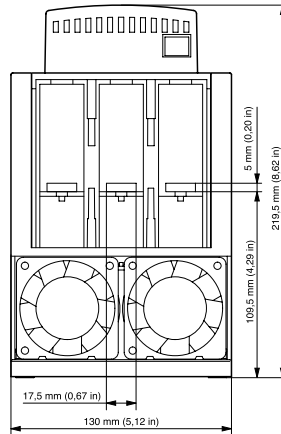

PSE210... 370

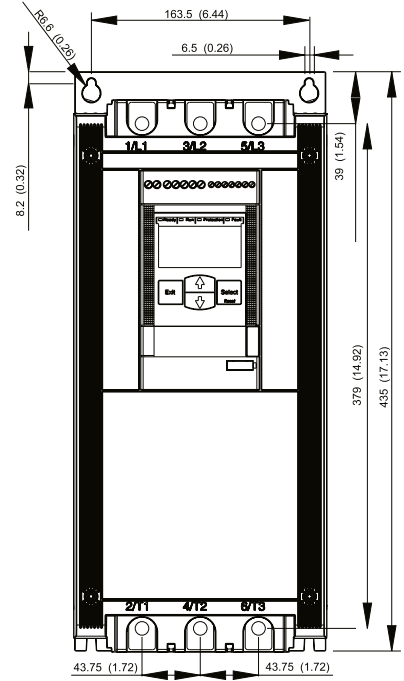
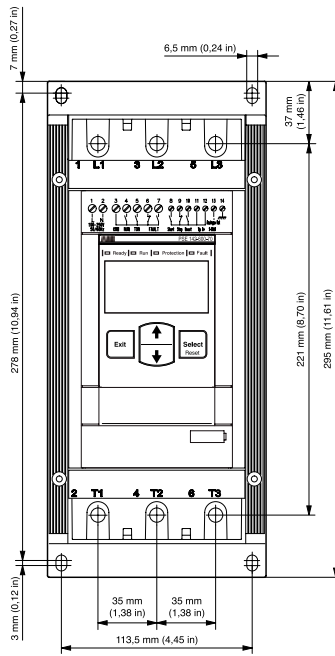
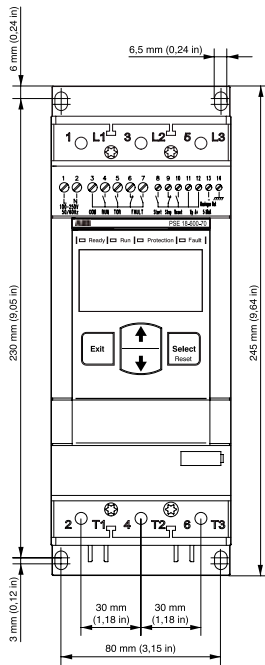
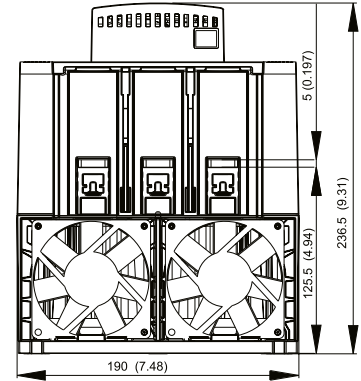

External keypad (PSEEK)

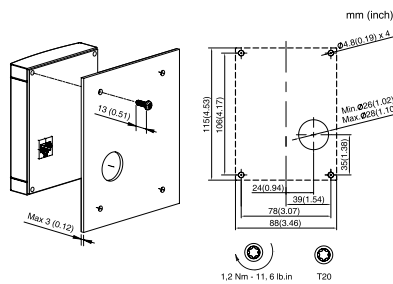
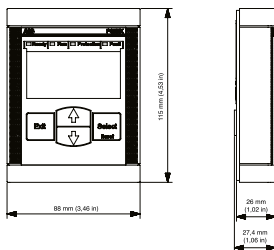

PSE - The efficient range

Circuit diagrams

PSE18... 370
With MCCB and line contactor

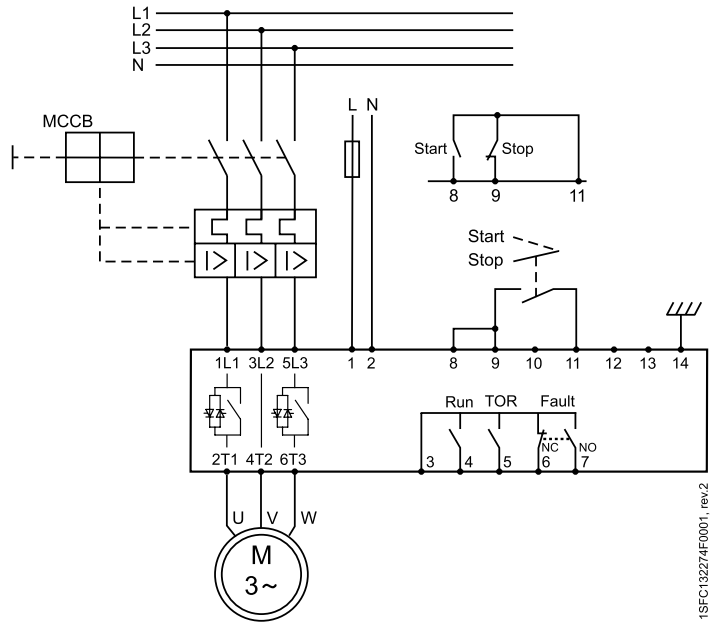

With fuses and line contactor

