



Technical catalogue - Preliminary

SACE FORMULA

New low voltage moulded-case
circuit-breakers up to 630A

Power and productivity
for a better world™



FORMULA



ABB

Main characteristics

1

Circuit-breakers for power distribution

2

Accessories

3

**Characteristic curves and
technical information**

4

Wiring diagrams

5

Overall dimensions

6

Glossary

7

SACE FORMULA.

Simplicity and Quality in a Single Product.



[FORMULA

SACE FORMULA is the expression of all ABB SACE's long experience of several decades in all its effectiveness: SACE FORMULA was born basic, but is able to amaze with its extreme versatility of use.

The main strong points of the new moulded-case circuit-breakers are:

- just a few but essential versions of the circuit-breakers, easy to select and order;
- availability of circuit-breakers of all polarities, dedicated to the various applications;
- possibility of using the accessories most often requested;
- circuit-breaker depths further reduced;
- a new installation system making assembly of the circuit-breakers easier;
- suitable for use at 50°C without derating.

LA



The new SACE FORMULA family consists of three new A1, A2 and A3 frames which reach up to 125A, 250A and 630A respectively.

The three frames are available in the fixed version, with front terminals.

The protection trip unit has fixed thermal and magnetic threshold values for putting the circuit-breaker into service more rapidly. This way selection becomes simple and precise. With a few sales codes which simplify selection and make ordering easier. Installation is simplified, and thanks to easy and rapid fixing operations and set-up, the circuit-breaker is ready for use immediately.

SACE FORMULA.

The Easy and Precise Choice.



How simple and functional can a range of moulded-case circuit-breakers be? It was answering this question, which would appear very elementary, that the idea for a new family of circuit-breakers was conceived at ABB SACE. The result is SACE FORMULA, the perfect synthesis between ABB SACE's recognized quality, reliability and all-round simplicity: with regards to installation, sizing and fitting with accessories. Reducing the dimensions without compromising on performance and reliability further helps installation, increasing the work space inside the switchboards. Compactness of dimensions is a great advantage, especially for OEMs, panel builders and installers.



SACE FORMULA. Winners in All Applications.

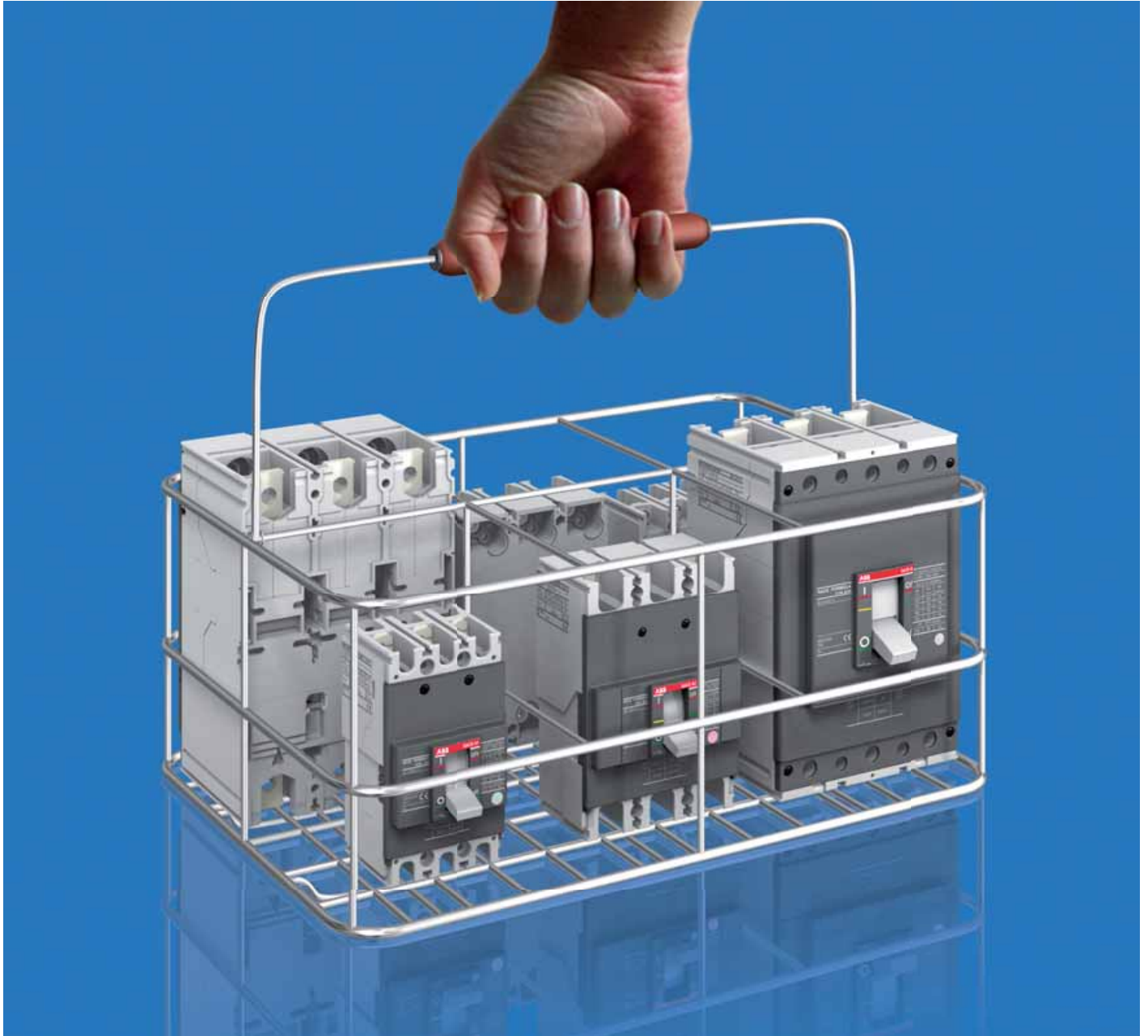

Quality is great versatility. In addition to proposing all three frames in the three-pole and four-pole version, for the first time ABB SACE now proposes single-pole and two-pole versions up to 250A, opening the door to the most varied application fields. Quality is compact overall dimensions. The SACE FORMULA A1 and A2 depth of just 60 mm is the lowest on the market up to 250A. Simplicity is this, too.



Main characteristics

Content

General information	1/2
Regulations and reference Standards	1/3
Identification of the SACE FORMULA circuit-breakers	1/4

Construction characteristics

General information



Double insulation

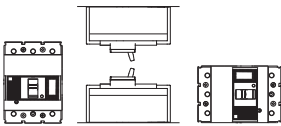

Installation positions



Positive operation

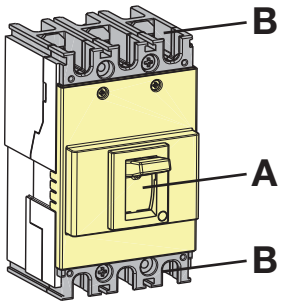

Protection degrees



Test pushbutton

The references in round brackets ^(Gx.x) in the technical catalogue refer to the Glossary in the final charter of the technical catalogue.

All the moulded-case circuit-breakers in the SACE FORMULA family are constructed in accordance with the following construction characteristics:

- double insulation^(G1.4);
- positive operation^(G1.5);
- isolation behaviour^(G1.6);
- electromagnetic compatibility^(G1.7);
- tropicalization^(G1.8);
- power supply from the top towards the bottom or vice versa;
- versatility of the installation. It is possible to mount the circuit-breaker either in the horizontal, vertical, or lying down position without undergoing any derating of the rated characteristics;
- no nominal performance derating for use up to an altitude of 2000m. Above 2000m, the properties of the atmosphere (composition of the air, dielectric strength, cooling power and pressure) change, having an impact on the main parameters which define the circuit-breaker. The table below gives the changes to the main performance parameters;

Altitude	2000m		3000m		4000m		5000m		
	A1	A2-A3	A1	A2-A3	A1	A2-A3	A1	A2-A3	
Rated service voltage, U _e	[V]	500	550	440	484	390	429	340	374
Rated uninterrupted current	%	100	100	98	98	95	95	90	90

- SACE FORMULA circuit-breakers can be used in ambient with a temperature between -25°C +70°C and stored in a room with atmospheric temperature between -40°C +70°C. SACE FORMULA circuit-breakers listed below are designed to hold 100% I_n at 50°C without tripping in normal condition:
 - SACE A1 and A2, up to 250A (except A1 125);
 - SACE A3 300-400A special version 50°C.

For detailed temperature performances of all SACE FORMULA breakers, please refer to paragraph "Temperature performances" in the Characteristic Curves and Technical Information Chapter;

- different protection degrees IP (International Protection) ^(G1.2);

	Circuit-breaker with front	Circuit-breaker without front ⁽¹⁾	Circuit-breaker with RHE RHD	Circuit-breaker with HTC	Circuit-breaker with LTC	Circuit-breaker with FLD
A	IP 40	IP 20	IP 40	IP 40	IP 40	IP 40
B	IP 20	IP 20	IP 20	IP 40	IP 30	IP 20

(1) During installation of the electrical accessories

- circuit-breaker weights;

Weights	A1 [Kg]	A2 [Kg]	A3 [Kg]
Circuit-breaker 1 pole	0.245	0.37	-
Circuit-breaker 2 poles	0.47	0.73	-
Circuit-breaker 3 poles	0.7	1.1	3.25
Circuit-breaker 4 poles	0.925	1.145	4.15

- all the SACE FORMULA circuit-breakers are fitted with a Test pushbutton which allows the release test to be done. This test must be carried out with the circuit-breaker closed.

Construction characteristics

Regulations and reference Standards



Hologram

Conformity with Standards

The SACE FORMULA circuit-breakers and their accessories are constructed in conformity with:

- Standards ^(G.4.1):
 - IEC 60947-2;
- Directives ^(G.4.2):
 - EC directive: “Low Voltage Directives” (LVD) no. 2006/95/CE (in replacement of 73/23/CEE and subsequent amendments);
 - EC directive: “Electromagnetic Compatibility Directive” (EMC) no. 89/336 EEC.

Certification of conformity with the product Standards is carried out in the ABB SACE test room (accredited by SINAL - certificate No. 062/1997-) in respect of the EN 45011 European Standard, by the Italian certification body ACAE (Association for Certification of Electrical Apparatus), member of the European LOVAG organisation (Low Voltage Agreement Group) and by the Swedish certification body SEMKO belonging to the international IECEE organisation.

The SACE FORMULA series has a hologram on the front, obtained using special anti-forgery techniques, a guarantee of the quality and genuineness of the circuit-breaker as an ABB SACE product.

Company Quality System

The ABB SACE Quality System conforms with the following Standards:

- ISO 9001 international Standard;
- EN ISO 9001 (equivalent) European Standards;
- UNI EN ISO 9001 (equivalent) Italian Standards;
- IRIS International Railway Industry Standards.

The ABB SACE Quality System attained its first certification with the RINA certification body in 1990.

Environmental Management System, Social Responsibility and Ethics

Attention to protection of the environment is a priority commitment for ABB SACE. Confirmation of this is the realisation of an Environmental Management System certified by RINA (ABB SACE was the first industry in the electromechanical sector in Italy to obtain this recognition) in conformity with the International ISO14001 Standard. In 1999 the Environmental Management System was integrated with the Occupational Health and Safety Management System according to the OHSAS 18001 Standard and later, in 2005, with the SA 8000 (Social Accountability 8000) Standard, committing itself to respect of business ethics and working conditions.

The commitment to environmental protection becomes concrete through:

- selection of materials, processes and packaging which optimise the true environmental impact of the product;
- use of recyclable materials;
- voluntary respect of the RoHS directive ^(G.4.3).

Construction characteristics

Identification of the SACE FORMULA circuit-breakers

The characteristics of the circuit-breakers are given on the label on the front of the circuit-breaker, and on the side label.

Front label

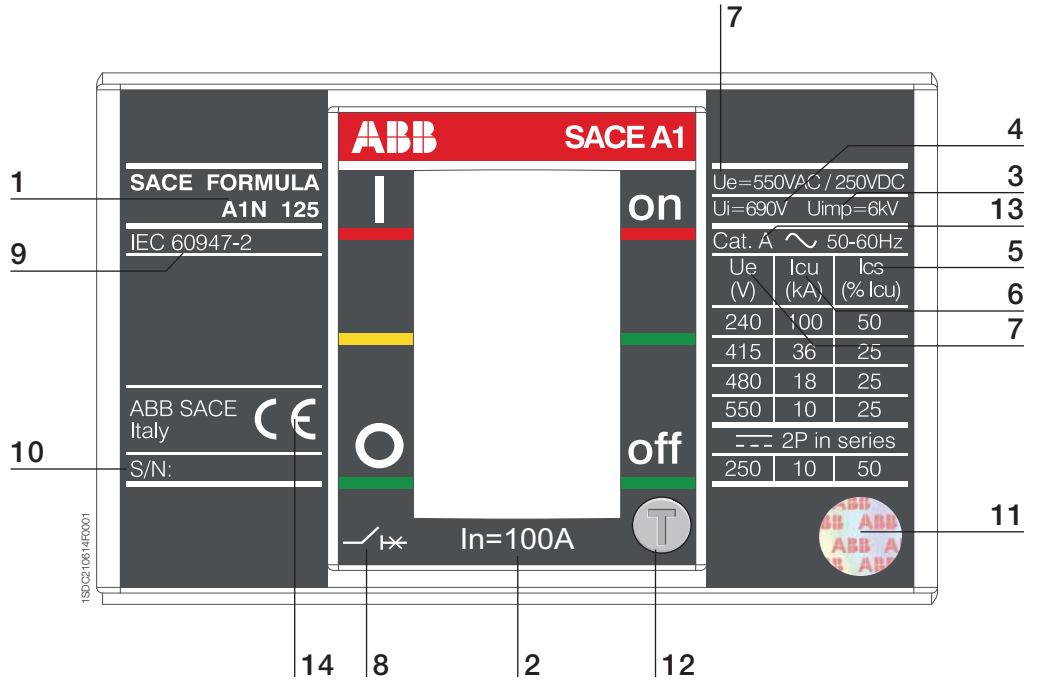

Side label

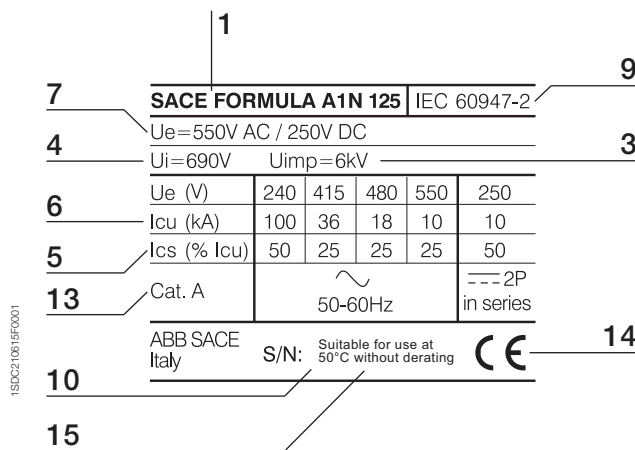

1. Name of the circuit-breaker and performance level;
2. In: rated uninterrupted current*;
3. Uimp: rated impulse withstand voltage*;
4. Ui: insulation voltage*;
5. Ics: rated short-circuit service breaking capacity*;
6. Icu: rated ultimate short-circuit breaking capacity*;
7. Ue: rated service voltage*;
8. Symbol of isolation behaviour*;
9. Reference Standard IEC 60947-2*;
10. Serial number;
11. Anti-forgery;
12. Test pushbutton;
13. Category of use;
14. CE Marking;
15. Utilization at 50°C (except for A1 125A).

* in compliance with the IEC 60947-2 Standard



Circuit-breakers for power distribution

Content

General characteristics	2/2
Thermomagnetic trip units	2/4
Ordering codes	2/5
Electronic trip units	2/9
Ordering codes	2/9

Circuit-breakers for power distribution

General characteristics

The SACE FORMULA circuit-breakers from 15A to 630A consist of the interruption part together with the trip unit and they can be installed:

- directly on the back plate of the cubicles;
- on a DIN rail (A1 and A2);
- back door (A1, A2 and A3, 2-3 4 poles).

They are characterised by:

- fixed version;
- polarity: 1 pole (A1 and A2), 2 poles (A1 and A2), 3 poles (A1, A2 and A3), 4 poles (A1, A2 and A3);
- maximum breaking capacity of 36kA for A1 and A2 and of 50kA for A3 at 415V AC;
- fixed thermomagnetic trip unit (TMF) for protection of networks in alternating and direct current (A1, A2, A3);
- ELT LI electronic trip unit with fixed thresholds for the protection of networks in alternating current (A3);
- only two depths: 60mm (A1, A2) and 103.5mm (A3);
- standard front terminals;
- the possibility of use at 50°C without derating up to 250A (except for A1 125A);
- a special version for A3 300A-400A for use at 50°C.

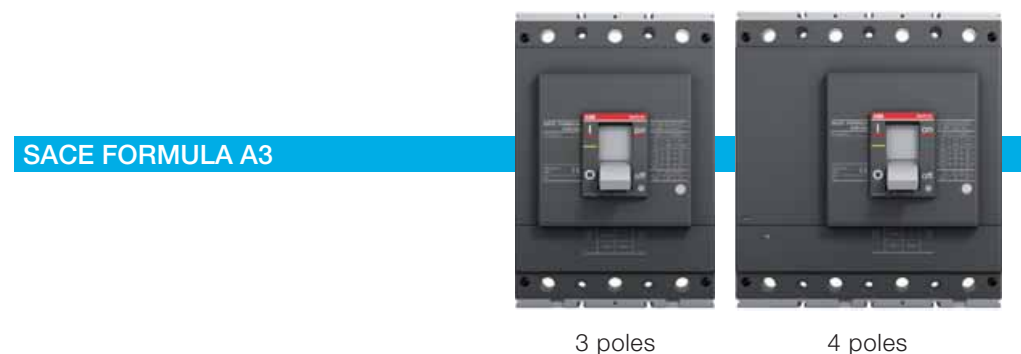
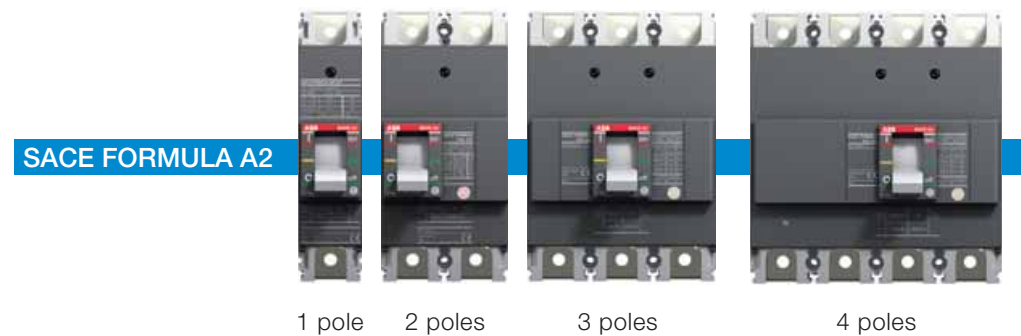
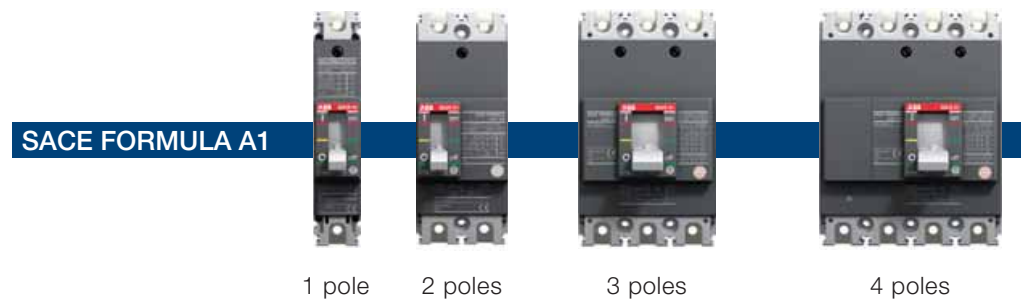

		A1						A2						A3		
Frame size ^(G2.1)	[A]	125						250						400/630		
Rated current, I_n ^(G2.2)	[A]	15...125						125...250						320...630		
Poles	[Nr]	1, 2, 3, 4						1, 2, 3, 4						3, 4		
Rated service voltage, U_e ^(G2.3)	(AC) 50-60 Hz	550 (2p-3p-4p); 415 (1p)						550 (2p-3p-4p); 415 (1p)						550		
	(DC)	250 (2p-3p-4p); 125 (1p)						250 (2p-3p-4p); 125 (1p)						250		
Rated insulation voltage, U_i ^(G2.4)	[V]	690						690						690		
Rated impulse withstand voltage, U_{imp} ^(G2.5)	[kV]	6						6						6		
Versions		Fixed						Fixed						Fixed		
Performance Level		A	B	C		N			B	C		N		N	S	
Poles	[Nr]	3/4	3/4	1	3/4	1	2	3/4	3/4	1	3/4	1	2	3/4	3/4	3/4
Rated ultimate short-circuit breaking capacity, I_{cu} ^(G2.6)																
I_{cu} @ 240 V 50-60 Hz (AC)	[kA]	10	25	18	30	25	50	100	25	18	50	25	50	85	85	100
I_{cu} @ 380 V 50-60 Hz (AC)	[kA]	10	18	2.5	25	5	36 ⁽⁵⁾	36 ⁽⁵⁾	18	2.5	25	5	36	36	36	50
I_{cu} @ 415 V 50-60 Hz (AC)	[kA]	10	18	2.5	25	5	36 ⁽⁵⁾	36 ⁽⁵⁾	18	2.5	25	5	36	36	36	50
I_{cu} @ 440 V 50-60 Hz (AC)	[kA]	8	15	-	20	-	25	25	15	-	20	-	25	25	36	50
I_{cu} @ 480 V 50-60 Hz (AC)	[kA]	7.5	10	-	15	-	18	18	15	-	18	-	18	25	25	35
I_{cu} @ 500 V 50-60 Hz (AC)	[kA]	5	5	-	8	-	10	10	5	-	8	-	10	10	20	25
I_{cu} @ 550 V 50-60 Hz (AC)	[kA]	5	5	-	8	-	10	10	5	-	8	-	10	10	15	20
I_{cu} @ 125 V (DC) 1 pole	[kA]	-	-	5	-	10	-	-	-	5	-	10	-	-	-	-
I_{cu} @ 250 V (DC) 2 poles in series	[kA]	5	5	-	10	-	10	10	18	-	25	-	10	36	36	50
Rated short-circuit service breaking capacity, I_{cs} ^(G2.7)																
I_{cs} @ 240 V 50-60 Hz (AC)	[kA]	50%	50%	50%	50%	50%	50%	50%	50%	50%	50%	50%	50%	50%	50%	50%
I_{cs} @ 380 V 50-60 Hz (AC)	[kA]	50%	50%	50%	50%	50%	50%	50%	50%	100%	50%	50%	50%	50%	50%	50%
I_{cs} @ 415 V 50-60 Hz (AC)	[kA]	50%	25% ⁽¹⁾	50%	25% ⁽²⁾	25%	25%	25%	50%	100%	50%	50%	50%	50%	50%	50%
I_{cs} @ 440 V 50-60 Hz (AC)	[kA]	50%	25% ⁽¹⁾	-	25%	-	25%	25%	50%	-	50%	-	50%	50%	50%	50%
I_{cs} @ 480 V 50-60 Hz (AC)	[kA]	50%	50%	-	25% ⁽¹⁾	-	25%	25% ⁽¹⁾	50%	-	50%	-	50%	50%	50%	50%
I_{cs} @ 500 V 50-60 Hz (AC)	[kA]	50%	50%	-	25% ⁽³⁾	-	25%	25%	50%	-	50%	-	50%	50%	50%	50%
I_{cs} @ 550 V 50-60 Hz (AC)	[kA]	50%	50%	-	25% ⁽³⁾	-	25%	25%	50%	-	50%	-	50%	50%	50%	50%
I_{cs} @ 250 V (DC) 2 poles in series	[kA]	50%	50%	50%	50%	50%	50%	50%	50%	50%	50%	50%	50%	50%	50%	50%
Rated short-circuit making capacity, I_{cm} ^(G2.8)																
I_{cm} @ 240 V 50-60 Hz (AC)	[kA]	52.5	52.5	36	63	52.5	105	220	52.5	36	105	52.5	105	187	187	220
I_{cm} @ 380 V 50-60 Hz (AC)	[kA]	17	36	3.8	52.5	7.5	75.6	75.6	36	3.8	52.5	7.5	75.6	75.6	75.6	105
I_{cm} @ 415 V 50-60 Hz (AC)	[kA]	17	36	3.8	52.5	7.5	63	63	36	3.8	52.5	7.5	75.6	75.6	75.6	105
I_{cm} @ 440 V 50-60 Hz (AC)	[kA]	13.6	30	-	40	-	52.5	52.5	30	-	40	-	52.5	52.5	75.6	105
I_{cm} @ 480 V 50-60 Hz (AC)	[kA]	12.8	17	-	30	-	36	17	30	-	36	-	36	52.5	52.5	73.5
I_{cm} @ 500 V 50-60 Hz (AC)	[kA]	7.5	7.5	-	13.6	-	17	17	7.5	-	13.6	-	17	17	40	52.5
I_{cm} @ 550 V 50-60 Hz (AC)	[kA]	7.5	7.5	-	13.6	-	17	17	7.5	-	13.6	-	17	17	30	40
Utilization category (IEC 60947-2) ^(G2.9)		A						A						A		
Hold 100% I_n at 50°C	[A]	15...100						125...250						300-400 ⁽⁴⁾		
Reference Standard		IEC 60947-2						IEC 60947-2						IEC 60947-2		
Isolation behaviour		■						■						■		
Fixing onto DIN rail		DIN EN 50022						DIN EN 50022						-		
Mechanical life ^(G2.10)	[No. operations]	8500						10000						5000		
Electrical life @ 415 V (AC) ^(G2.11)	[No. operations]	1500						4000						2000		
Total opening time	Shunt opening release (SOR)	15						15						15		
	Undervoltage release (UVR)	15						15						≤ 25		
Dimensions (Width x Depth x Height)	1 pole	25.4x60x130						35x60x150						-		
	2 poles	50.8x60x130						70x60x150						-		
	3 poles	76.2x60x130						105x60x150						139.5x 103.5x 205		
	4 poles	101.6x60x130						140x60x150						186x 103.5x 205		
Weight	1 pole	0.245						0.370						-		
	2 poles	0.470						0.730						-		
	3 poles	0.700						1.100						3.25		
	4 poles	0.925						1.450						4.15		
Trip Unit ^(G3.1)																
Thermomagnetic TMF ^(G3.2)		■						■						■ (up to 500A)		
Electronic ELT LJ ^(G3.3)		■						■						■ (up to 630A)		

⁽¹⁾ 5kA; ⁽²⁾ 9kA; ⁽³⁾ 2.5kA; ⁽⁴⁾ Special version; ⁽⁵⁾ $I_n=15A$, $I_{cu}=30kA$

Circuit-breakers for power distribution

Thermomagnetic trip unit

The thermomagnetic trip units TMF, available for A1, A2 and A3, with fixed thermal and magnetic threshold, are generally used in power distribution plants. They allow protection against overloads thanks to the thermal device and protection against short-circuit thanks to magnetic device:

- thermal protection (L): fixed threshold $I_1 = 1 \times I_n$, with long inverse time trip curve;
- magnetic protection (I): fixed threshold $I_3 = 10 \times I_n$, with instantaneous trip curve;
- neutral at 100% for four-pole circuit-breakers.

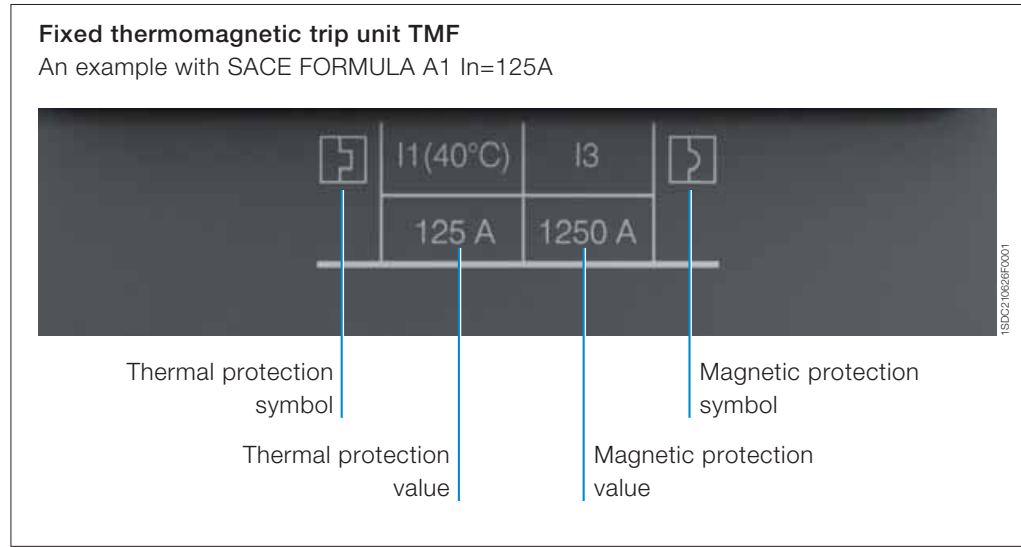

SACE FORMULA A1 with trip unit TMF

TMF																	
L $I_1 = 1 \times I_n$	I_n [A]	15	16	20	25	30	32	40	50	60	63	70	80	90	100	125	
	Neutral [A] - 100%	15	16	20	25	30	32	40	50	60	63	70	80	90	100	125	
I $I_3 = 10 \times I_n$	I_3 [A]	300	300	300	300	300	320	400	500	600	630	700	800	900	1000	1250	
	Neutral [A] - 100%	300	300	300	300	300	320	400	500	600	630	700	800	900	1000	1250	

SACE FORMULA A2 with trip unit TMF

TMF									
L $I_1 = 1 \times I_n$	I_n [A]	125	150	160	175	200	225	250	
	Neutral [A] - 100%	125	150	160	175	200	225	250	
I $I_3 = 10 \times I_n$	I_3 [A]	1250	1500	1600	1750	2000	2250	2500	
	Neutral [A] - 100%	1250	1500	1600	1750	2000	2250	2500	

SACE FORMULA A3 with trip unit TMF

TMF				
L $I_1 = 1 \times I_n$	I_n [A]	320	400	500
	Neutral [A] - 100%	320	400	500
I $I_3 = 10 \times I_n$	I_3 [A]	3200	4000	5000
	Neutral [A] - 100%	3200	4000	5000

Ordering codes for circuit-breakers with thermomagnetic trip units



1SDC210627F001

A1 125A - Fixed (F) 1 pole - Front terminals (F) - Hold 100% In at 50°C

Thermomagnetic trip unit - TMF Icu (240 V)

1SDA...R1			
In	I3	C (18kA)	N (25kA)
15	400	066485	
16	400	068745	
20	400	066486	066686
25	400	066487	066687
30	400	066488	066688
32	400	068754	068755
40	400	066489	066689
50	500	066490	066690
60	600	066491	066691
63	630	068765	068766
70	700	066492	066692
80	800	066493	066693
90	900	066494	066694
100	1000	066495	066695
125	1250	066496 ⁽¹⁾	066696 ⁽¹⁾

⁽¹⁾ Derating for use at 50°C



1SDC210628F001

A1 125A - Fixed (F) 2 poles - Front terminals (F) - Hold 100% In at 50°C

Thermomagnetic trip unit - TMF Icu (415 V)

1SDA...R1		
In	I3	N (36kA)
15	400	068789 ⁽²⁾
16	400	068790
20	400	066497
25	400	066498
30	400	066499
32	400	068756
40	400	066500
50	500	066501
60	600	066502
63	630	068767
70	700	066503
80	800	066504
90	900	066505
100	1000	066506
125	1250	066507 ⁽¹⁾

⁽¹⁾ Derating for use at 50°C; ⁽²⁾ 30kA

Circuit-breakers for power distribution

Thermomagnetic trip unit

Ordering codes for circuit-breakers with thermomagnetic trip units



A1 125A - Fixed (F) 3 poles - Front terminals (F) - Hold 100% In at 50°C

Thermomagnetic trip unit - TMF I_{cu} (415 V)

1SDA...R1					
In	I ₃	A (10kA)	B (18kA)	C (25kA)	N (36kA)
15	300	066510	066697	066709	066721 ⁽²⁾
16	300	068746	068747	068748	068749 ⁽²⁾
20	300	066511	066698	066710	066722
25	300	066512	066699	066711	066723
30	300	066513	066700	066712	066724
32	320	068757	068758	068759	068760
40	400	066514	066701	066713	066725
50	500	066515	066702	066714	066726
60	600	066516	066703	066715	066727
63	630	068768	068769	068770	068771
70	700	066517	066704	066716	066728
80	800	066518	066705	066717	066729
90	900	066519	066706	066718	066730
100	1000	066520	066707	066719	066731
125	1250	066521 ⁽¹⁾	066708 ⁽¹⁾	066720 ⁽¹⁾	066732 ⁽¹⁾

⁽¹⁾ Derating for use at 50°C; ⁽²⁾ 30kA



A1 125A - Fixed (F) 4 poles - Front terminals (F) - Hold 100% In at 50°C

Thermomagnetic trip unit - TMF I_{cu} (415 V)

1SDA...R1					
In	I ₃	A (10kA)	B (18kA)	C (25kA)	N (36kA)
15	300	066524	066733	066745	066757 ⁽²⁾
16	300	068750	068751	068752	068753 ⁽²⁾
20	300	066525	066734	066746	066758
25	300	066526	066735	066747	066759
30	300	066527	066736	066748	066760
32	320	068761	068762	068763	068764
40	400	066528	066737	066749	066761
50	500	066529	066738	066750	066762
60	600	066530	066739	066751	066763
63	630	068772	068773	068774	068775
70	700	066531	066740	066752	066764
80	800	066532	066741	066753	066765
90	900	066533	066742	066754	066766
100	1000	066534	066743	066755	066767
125	1250	066535 ⁽¹⁾	066744 ⁽¹⁾	066756 ⁽¹⁾	066768 ⁽¹⁾

⁽¹⁾ Derating for use at 50°C; ⁽²⁾ 30kA



A2 250A - Fixed (F) 1 pole - Front terminals (F) - Hold 100% In at 50°C

Thermomagnetic trip unit - TMF I_{cu} (240 V)

		1SDA...R1		
In	I ₃	C (18kA)	N (25kA)	
125	1250	066536	066769	
150	1500	068776	068777	
160	1600	066537	066770	
175	1750	066538	066771	
200	2000	066539	066772	
225	2250	066540	066773	
250	2500	066541	066774	



A2 250A - Fixed (F) 2 poles - Front terminals (F) - Hold 100% In at 50°C

Thermomagnetic trip unit - TMF I_{cu} (415 V)

		1SDA...R1		
In	I ₃	N (36kA)		
125	1250	066542		
150	1500	068778		
160	1600	066543		
175	1750	066544		
200	2000	066545		
225	2250	066546		
250	2500	066547		



A2 250A - Fixed (F) 3 poles - Front terminals (F) - Hold 100% In at 50°C

Thermomagnetic trip unit - TMF I_{cu} (415 V)

		1SDA...R1		
In	I ₃	B (18kA)	C (25kA)	N (36kA)
125	1250	066548	066775	066781
150	1500	068779	068780	068781
160	1600	066549	066776	066782
175	1750	066550	066777	066783
200	2000	066551	066778	066784
225	2250	066552	066779	066785
250	2500	066553	066780	066786



A2 250A - Fixed (F) 4 poles - Front terminals (F) - Hold 100% In at 50°C

Thermomagnetic trip unit - TMF I_{cu} (415 V)

		1SDA...R1		
In	I ₃	B (18kA)	C (25kA)	N (36kA)
125	1250	066554	066787	066793
150	1500	068782	068783	068784
160	1600	066555	066788	066794
175	1750	066556	066789	066795
200	2000	066557	066790	066796
225	2250	066558	066791	066797
250	2500	066559	066792	066798

Circuit-breakers for power distribution

Thermomagnetic trip unit

Ordering codes for circuit-breakers with thermomagnetic trip units



A3 400A - Fixed (F) 3 poles - Front terminals (F)

Thermomagnetic trip unit - TMF I_{cu} (415 V)

1SDA...R1			
In	I ₃	N (36kA)	S (50kA)
320	3200	066560	066562
400	4000	066561	066563

A3 630A - Fixed (F) 3 poles - Front terminals (F)

Thermomagnetic trip unit - TMF I_{cu} (415 V)

1SDA...R1			
In	I ₃	N (36kA)	S (50kA)
500	5000	066564	066565



A3 400A - Fixed (F) 4 poles - Front terminals (F)

Thermomagnetic trip unit - TMF I_{cu} (415 V)

1SDA...R1			
In	I ₃	N (36kA)	S (50kA)
320	3200	066568	066570
400	4000	066569	066571

A3 630A - Fixed (F) 4 poles - Front terminals (F)

Thermomagnetic trip unit - TMF I_{cu} (415 V)

1SDA...R1			
In	I ₃	N (36kA)	S (50kA)
500	5000	066572	066573

Ordering codes A3 special version 50°C

A3 400A - Fixed (F) 3 poles - Front terminals (F) - Hold 100% In at 50°C

Thermomagnetic trip unit - TMF I_{cu} (415 V)

1SDA...R1			
In	I ₃	N (36kA)	S (50kA)
300	3000	068809	068960
400	4000	068810	068961

Circuit-breakers for power distribution

Electronic trip unit

The ELT LI electronic trip unit, only available for A3, provides protection functions against overload L and short-circuit I:

- protection against overload (L): fixed threshold $I_1=630A$, with long inverse time trip curve;
- protection against short-circuit (I): fixed threshold $I_3=6000A$, with instantaneous time trip curve;
- neutral at 100% for four-pole circuit-breakers.

ELT LI fixed electronic trip unit

An example with SACE FORMULA A3 $I_n=630A$

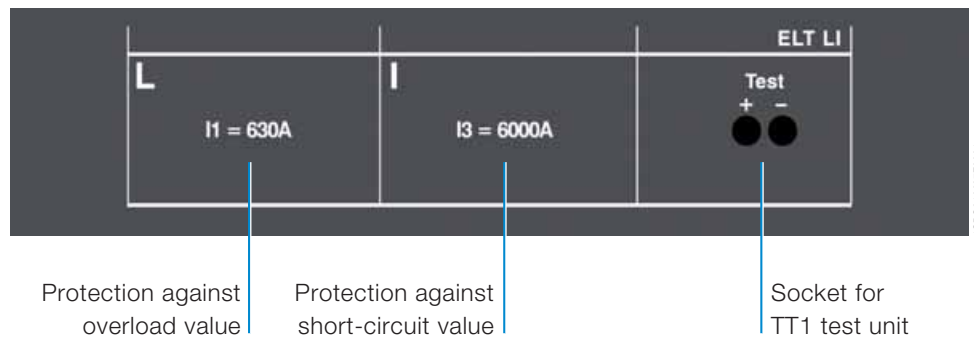

SACE FORMULA A3 with trip unit ELT LI

Protection function	Trip threshold	Trip curve	Excludability	Relation
L Against overload with long inverse time delay trip according to IEC 60947-2 Standard	Fixed threshold $I_1=630A$ Tolerance: trip between 1.1...1.30xI1	$t_1 = 12\text{ s}$ at $6xI_1$ Tolerance: $\pm 10\%$ up to $6xI_n$ $\pm 20\%$ above $6xI_n$	no	$t=k/I^2$
I Against short-circuit with instantaneous trip with fixed threshold	Fixed threshold $I_3=6000A$ Tolerance: $\pm 10\%$	instantaneous	no	$t=k$

Ordering codes for circuit-breakers with electronic trip units



A3 630A - Fixed (F) 3 poles - Front terminals (F)

Electronic trip unit - ELT LI Icu (415 V)

1SDA...R1			
In	I3	N (36kA)	S (50kA)
630	6000	066566	066567

A3 630A - Fixed (F) 4 poles - Front terminals (F)

Electronic trip unit - ELT LI Icu (415 V)

1SDA...R1			
In	I3	N (36kA)	S (50kA)
630	6000	066574	066575

Trip test unit

TT1 - Trip test unit	1SDA...R1
	037121



Content

Panorama of accessories	3/2
Mechanical accessories	
Connection terminals.....	3/4
Ordering codes	3/6
Terminal covers, phase separators and sealable screws	3/7
Ordering codes	3/7
Rotary handle operating mechanism.....	3/8
Ordering codes	3/8
Front for lever operating mechanism.....	3/9
Ordering codes	3/9
Locks	3/9
Ordering codes	3/10
Bracket for fixing onto DIN rail	3/11
Ordering codes	3/11
Electrical accessories	
Service releases.....	3/12
Ordering codes	3/13
Auxiliary contacts for electric signals.....	3/14
Ordering codes	3/14
FORMULA Link.....	3/16
Ordering codes	3/19

Accessories

Panorama of the accessories

SACE FORMULA A1 - A2

1 pole accessories

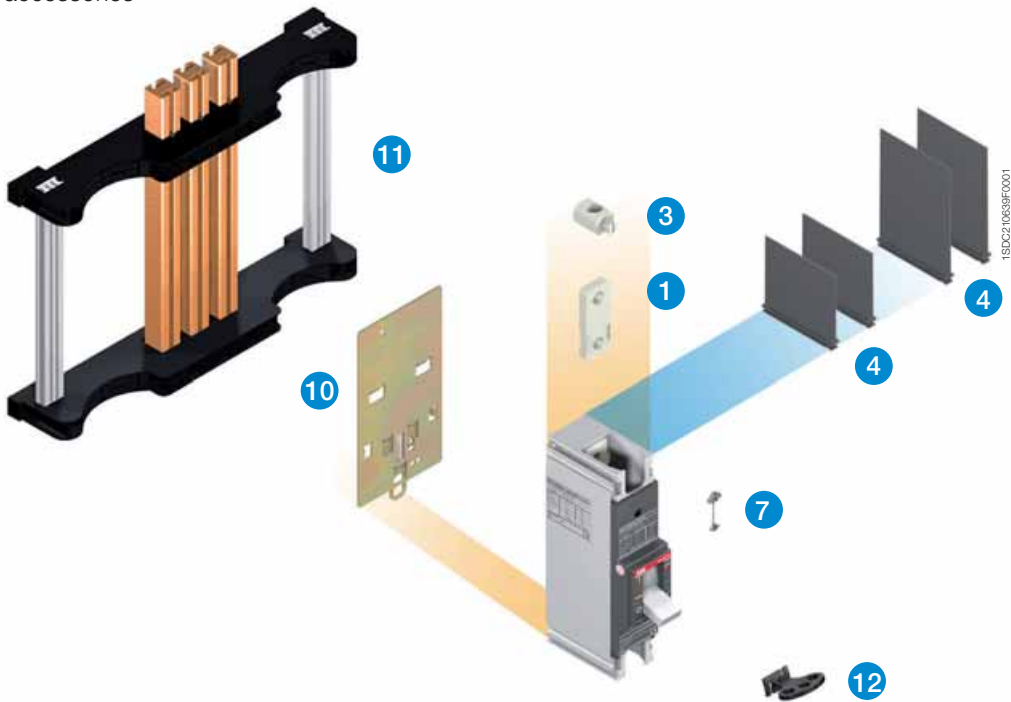

SACE FORMULA A1 - A2

2 poles accessories

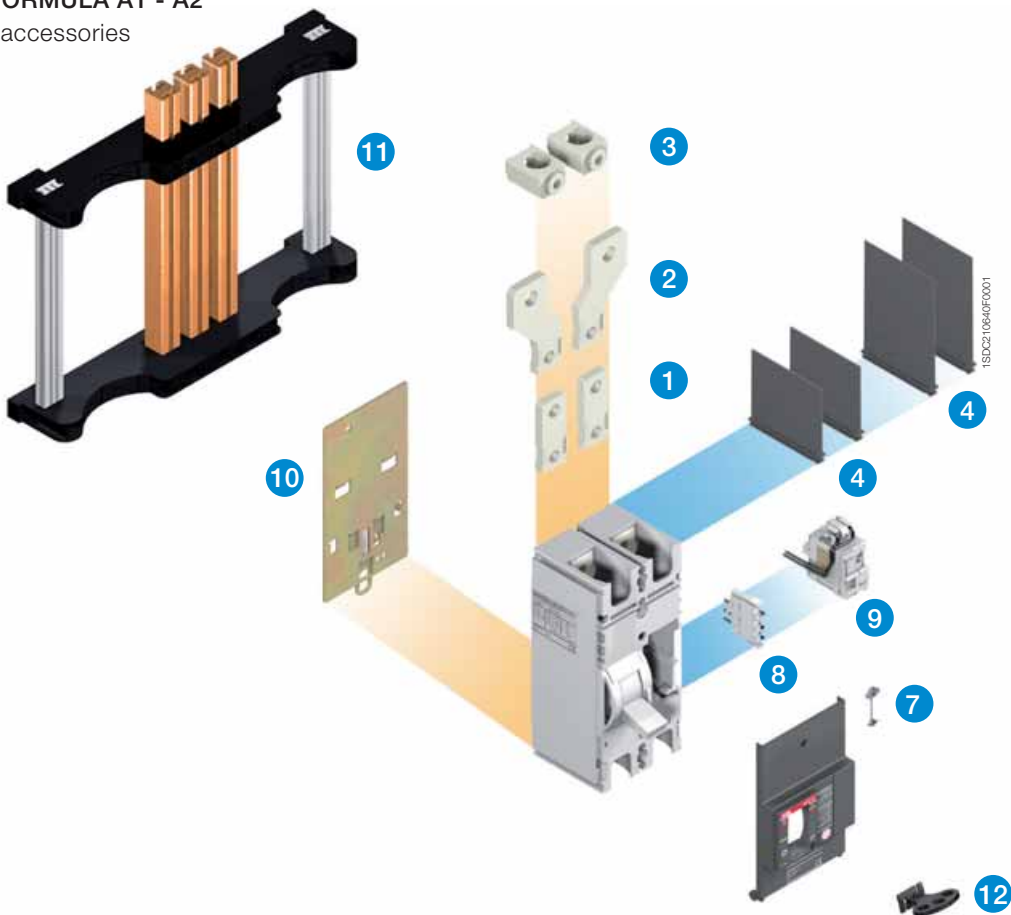

The assembly of all the SACE FORMULA accessories has to be provided by the Customer.

SACE FORMULA A1 - A2 - A3
3poles/4poles accessories

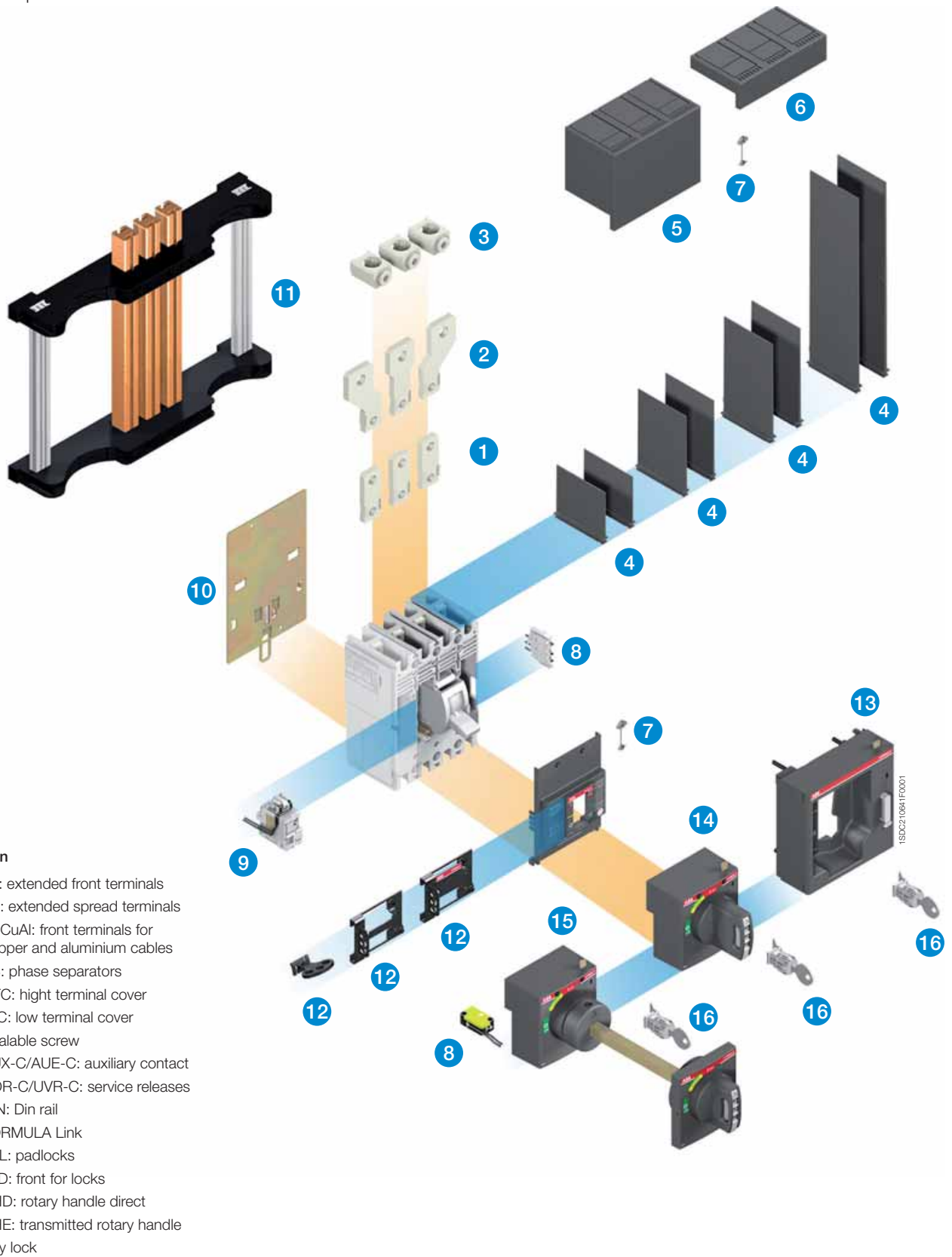

Caption

- 1 EF: extended front terminals
- 2 ES: extended spread terminals
- 3 FCCuAl: front terminals for copper and aluminium cables
- 4 PS: phase separators
- 5 HTC: high terminal cover
- 6 LTC: low terminal cover
- 7 Sealable screw
- 8 AUX-C/AUE-C: auxiliary contact
- 9 SOR-C/UVR-C: service releases
- 10 DIN: Din rail
- 11 FORMULA Link
- 12 PLL: padlocks
- 13 FLD: front for locks
- 14 RHD: rotary handle direct
- 15 RHE: transmitted rotary handle
- 16 Key lock

The assembly of all the SACE FORMULA accessories has to be provided by the Customer.

Accessories

Mechanical accessories

Connection terminals

The connection terminals allow the circuit-breaker to be connected to the plant in the most suitable way in relation to installation requirements.

The front terminals allow cables or busbars to be connected acting directly from the front of the circuit-breaker (cable lugs to be provided by the Customer).

Different types of terminals can be combined (one type for the line and a different one for the load side).

Standard version of circuit-breaker is supplied with front terminals (F). By ordering the special kits or half-kits, it is also possible to select among the following types:

- front extended terminals (EF);
- front extended spread terminals (ES);
- front terminals for Copper and Aluminium cables (FCCuAl).

Front terminals - F

Type	Poles	Busbar dimensions MAX				Cable lug [mm]		Tightening torques [Hole dimension] and [Nm]				Terminal covers [mm]				Separators [mm]			
		W	H	D	ø	W	ø	Terminal	Cable or busbar	2	7.5	50	60	50	80	100	200		
A1	1 2 3 4	15	6	5	6.5	15	6.5	-	-	M6	4	-	-	R	-	S	-	R	-
A2 ⁽¹⁾	1 2 3 4	25	8	6	8.5	24	8.5	-	-	M8	8	-	-	-	R	-	S	R	-
A3	3 4	35	11	10	10.5	35	10.5	-	-	M10	28	R	-	-	R	-	-	R	R

(1) Insulation of the switchboard door and insulating plate on the back of the circuit-breaker for use at Ue≥415 V mandatory.



Terminal F



Terminal F with cable lug



Terminal F with busbar

Front Extended Terminals - EF

Type	Poles	Busbar dimensions MAX			Cable lug [mm]		Tightening torques [Hole dimension] and [Nm]				Terminal covers [mm]				Separators [mm]			
		W	D	ø	W	ø	Terminal	Cable or busbar	2	7.5	50	60	50	80	100	200		
A1	1 2 3 4	15	5	8.5	15	8.5	M6	3	M8	9	-	-	R	-	^[2]	-	R	-
A2 ⁽¹⁾	1 2 3 4	25	6	9	NA	NA	M8	8	M8	9	-	-	-	R	-	^[2]	R	-
A3	3 4	30	7	11	30	11	M10	28	M10	18	-	-	-	R	-	-	S	R

(1) Insulation of the switchboard door and insulating plate on the back of the circuit-breaker for use at Ue≥415 V mandatory.

(2) In EF terminal kit the phase separators are not provided, but for a correct installation it is necessary to use the phase separators already provided with the circuit-breakers base.



Terminal EF



Terminal EF with busbar

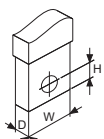

NA = Not available
W = Width
H = Hole height
D = Depth
ø = Diameter
S = Standard
R = On request

Front Extended Spread Terminal - ES

Type	Poles	Busbar dimensions MAX			Cable lug [mm]		Tightening torques [Hole dimension] and [Nm]				Terminal covers [mm]				Separators [mm]			
		W	D	ø	W	ø	Terminal	Cable or busbar	2	7.5	50	60	50	80	100	200		
A1	2 3 4	20	6	8.5	20	8.5	M6	3	M8	9	-	-	-	-	-	-	S	-
A2 ⁽¹⁾	2 3 4	30	4	10.5	NA	NA	M8	8	M10	18	-	-	-	-	-	-	S	-
A3	3 4	40	10	11	11	11	M10	28	M10	18	-	-	-	-	-	-	-	S

(1) Insulation of the switchboard door and insulating plate on the back of the circuit-breaker for use at Ue≥415 V mandatory.



Terminal ES



Terminal ES with cable lug



Terminal ES with busbar

Front Terminals for copper aluminium cables - FCCuAl

Type	Assembly	Poles	Cable [mm ²]		Tightening torques [Hole dimension] and [Nm]				Length of Cable stripping [mm]	Terminal covers [mm]				Separators [mm]				
			Rigid	Flexible	Terminal	Cable or busbar	2	7.5		50	60	50	80	100	200			
A1	Internal	1 ⁽¹⁾ 2 ⁽¹⁾ 3 4	1x1..25	1x2.5..25	M6	3	-	1-4mm ² : 1Nm 5-25mm ² : 3Nm	16	-	S ⁽¹⁾	R	-	-	-	-	-	-
A1	Internal	1 ⁽¹⁾ 2 ⁽¹⁾ 3 4	1x25..50	1x25..50	M6	3	-	3	16	-	S ⁽¹⁾	R	-	-	-	-	-	-
A2 ⁽³⁾	Internal	1 ⁽²⁾ 2 ⁽²⁾ 3 4	1x50..150	1x70..120	M8	5	-	15	20	-	S ⁽¹⁾	-	R	-	-	-	-	-
A2 ⁽³⁾	Internal	1 ⁽²⁾ 2 ⁽²⁾ 3 4	1x150..185	-	M8	5	-	20	22	-	S ⁽¹⁾	-	R	-	-	-	-	-
A3	Internal	3 4	1x185..300	-	M10	18	M16	43	23.5	R	-	-	R	-	-	R	R	-
A3	External	3 4	2x95..240	-	M10	18	M22	31	30 ^{1°cable/70°2°cable}	-	-	-	S	-	-	-	-	-

(1) The Terminal covers are not supplied for 1p and 2p, the use of phase separators, supplied with the standard circuit-breaker, and the insulating of switchboard door are necessary.

(2) Insulation plate on the back of the circuit-breaker as mandatory.

(3) If terminals are mounted on top of circuit-breaker, Icu=50% and Ics=Icu.



Terminal FCCuAl



Terminal FCCuAl with cable



External terminal FCCuAl



External terminal FCCuAl
with cable

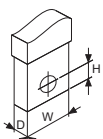

NA = Not available
W = Width
H = Hole height
D = Depth
ø = Diameter
S = Standard
R = On request

Accessories

Mechanical accessories

Ordering codes connection terminals

Terminals

1SDA...R1						
Front terminals - F	1 piece	2 pieces	3 pieces	4 pieces	6 pieces	8 pieces
A1	066200	066201	066202	066203	066204	066205
A2	066206	066207	066208	066209	066210	066211
A3			055012	055013	055010	055011

1SDA...R1						
Front Extended Terminals - EF	1 piece	2 pieces	3 pieces	4 pieces	6 pieces	8 pieces
A1	066212	066213	066214	066215	066216	066217
A2	066218	066219	066220	066221	066222	066223
A3			055036	055037	055034	055035

1SDA...R1						
Front Extended Spread Terminal - ES		2 pieces	3 pieces	4 pieces ⁽¹⁾	6 pieces	8 pieces
A1		066224	066225	066226	066227	066228
A2		066229	066230	066231	066232	066233
A3			055040	055041	055038	055039

1SDA...R1						
Front Terminals for copper aluminium cables - FCCuAl	1 piece	2 pieces	3 pieces	4 pieces	6 pieces	8 pieces
A1 1 x 1...25 mm ²	066234	066235	066236	066237	066238	066239
A1 1 x 25...50 mm ²	066240	066241	066242	066243	066244	066245
A2 1 x 50...150 mm ² ⁽²⁾	066246	066247	066248	066249	066250	066251
A2 1 x 125...185 mm ² ⁽²⁾	066252	066253	066254	066255	066256	066257
A3 1 x 185...300 mm ²			055024	055025	055022	055023
A3 2 x 95...240 mm ²			055032	055033	055030	055031

(1) 4 poles circuit-breakers only.

(2) If terminals are mounted on top of circuit-breaker, I_{cu}=50% and I_{cs}=I_{cu}.



High terminal cover (HTC)



Low terminal cover (LTC)



Sealable screw

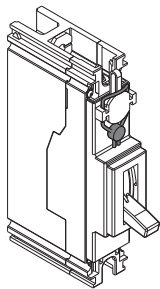

Sealable screw onto the circuit-breaker front

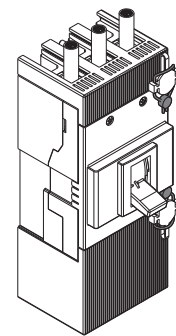

Sealable screw onto the terminal covers

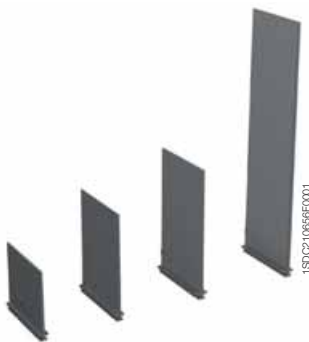

Phase separators (PS)

Terminal covers, phase separators and sealable screws

The terminal both high (HTC) and low (LTC) covers are applied to the circuit-breaker to avoid accidental contacts with live parts and, in this way, to guarantee protection against direct contacts. The terminal covers are pre-punched for knock-out on the front to facilitate installation of busbars and/or cables, guaranteeing correct insulation.

The phase separator partitions (PS) allow the insulation characteristics between phases to be increased near the connections. They are mounted on the front, even with the circuit-breaker already installed, by inserting them into the corresponding slots. The phase separators are incompatible with both the high and the low terminal covers.

The lead sealing kit consists of screws which, when applied onto the terminal covers or onto the circuit-breaker front, prevent their removal, acting as a protection against direct contacts and tampering. The screws can be locked with a wire and sealed with lead.

The compulsory and optional phase separators and terminal covers needed for correct installation and insulation of the circuit-breaker are indicated in the "Connection terminals" section of the Accessories chapter and in the "Overall dimension" chapter, in correspondence with each usable terminal.

Ordering codes terminal covers, phase separators and sealable screws

Terminal covers

	1SDA...R1					
	A1		A2		A3	
	3 poles	4 poles	3 poles	4 poles	3 poles	4 poles
HTC 60mm			066186	066189	054960	054961
HTC 50mm	066190	066185				
LTC 7.5mm	066181	066182	066183	066184		
LTC 2mm					054968	054969
Sealable screws for terminal cover	066673		066673		051504	
Sealable screws for front	068214		068214			

Phase separators

	1SDA...R1							
	A1			A2			A3	
	2 pieces	4 pieces	6 pieces	2 pieces	4 pieces	6 pieces	4 pieces	6 pieces
PS 50mm	066191	066194	066197					
PS 80mm				066192	066195	066198		
PS 100mm	066193	066196	066199	066193	066196	066199	054970	054971
PS 200mm							054972	054973

Accessories

Mechanical accessories



Direct handle (RHD)



Transmitted handle (RHE)

Rotary handle operating mechanism

Rotary handle operating mechanism is a control device which allows the circuit-breaker to be operated by means of a rotary handle, which facilitates circuit-breaker opening and closing thanks to its ergonomic handgrip.

There are two types of handle:

- direct (RHD): installed directly on the front of the circuit-breaker;
- transmitted (RHE): installed on the switchboard door, it acts on the circuit-breaker installed on the back of the switchboard by means of a transmission rod.

The rotary handles, in the direct and transmitted version, are available for the three-pole and four-pole A1, A2 and A3 circuit-breakers both in the standard version (grey) and in the emergency version (red on a yellow background) suitable for controlling machine tools.

Information/settings visible and accessible to the user:

- circuit-breaker nameplate;
- indication of the 3 positions: open (OFF), closed (ON), tripped (TRIP);
- access to the test pushbutton of rotary handle release (only RHD).

The rotary handle operating mechanisms can be ordered:

- by using the code of the version already configured (RHD and RHE);
- by composing the following three devices (only RHE):
 - rotary handle on door of the compartment: standard (RHE_H) or emergency (RHE_H_EM);
 - transmission rod of 500mm (RHE_S). The minimum and maximum distances between the fixing surface and the door are 62.5mm and 479.5mm;
 - base for circuit-breaker (RHE_B).

It is possible to accessorize the handles by means of a vast range of key locks and padlocks. Each rotary handle takes up to maximum 3 padlocks (7mm Ø stem). [See the "Locks" paragraph in the Accessories chapter].

The direct and transmitted rotary handle allows use of the early auxiliary contacts on closing so as to supply the undervoltage release with power early in relation to closing of the main circuit-breaker contacts [see the "Early auxiliary contacts" paragraph in the Accessories chapter].

Ordering codes rotary handle operating mechanism

Rotary Handle

	1SDA...R1	
	A1-A2	A3
RHD - Operating mechanism direct handle	066154	066155
RHD EM - Operating mechanism emergency direct handle	066156	066157
RHE - Operating mechanism transmitted handle	066158	066159
RHE EM - Operating mechanism emergency transmitted handle	066160	066161
RHE_S - Rod transmitted handle	066164	068952
RHE_B - Base transmitted handle	066162	066163
RHE_H - Transmitted handle	066165	066167
RHE_H_EM - Emergency transmitted handle	066166	066168



Front for locks (FLD)

Front for lever operating mechanism

Device which can be installed on the front of the circuit-breaker, which allows the circuit-breaker to be locked with keys and padlocks.

The front for the lever operating mechanism can only be installed on the A3 circuit-breaker in the three-pole or four-pole version. It is possible to lock the front for the lever operating mechanism by means of a vast range of key locks and padlocks. [See the “Locks” paragraph in the Accessories chapter]

Ordering codes front for lever operating mechanism

Front for operating mechanism

1SDA...R1	
A3	
FLD - Front for locks	066179



Fixed padlock in open position (PLL)

Locks

Devices (with padlocks or keys) which prevent the circuit-breaker closing or opening operation. They can be applied:

- directly onto the front of the circuit-breaker;
- onto the direct/transmitted rotary handle operating mechanism;
- onto the front for lever operating mechanisms.

All the locks of the circuit-breaker in the open position ensure isolation of the circuit according to the IEC 60947-2 Standard. The locks in closed position do not prevent release of the mechanism following a fault.



Fixed padlock in open and closed position (PLL)



Removable padlock in open position (PLL)

Type of lock	Circuit-breaker	Polarity	Optional/Standard Supply	CB lock position	Type of Lock	Withdrawability of Key	
Circuit-breaker	PLL- Fixed padlock	A1-A2	3, 4	Optional	OPEN-CLOSED	padlocks-max 3 padlocks Ø stem 7mm (not supplied)	-
	PLL- Fixed padlock	A1-A2	3, 4	Optional	OPEN	padlocks-max 3 padlocks Ø stem 7mm (not supplied)	-
	PLL- Removable padlock	A1-A2	1,2,3,4	Optional	OPEN	padlocks-max 3 padlocks Ø stem 7mm (not supplied)	-
Rotary Handle Direct and Transmitted	Padlock in open position	A1-A2-A3	3,4	Standard	OPEN	padlocks-max 3 padlocks Ø stem 7mm (not supplied)	-
	Compartment door lock	A1-A2-A3	3,4	Standard	CLOSED	Door lock ⁽¹⁾	-
	RHL-S Lock with key in open pos.	A1-A2-A3	3,4	Optional	OPEN	Same Ronis keys	OPEN
	RHL-D Lock with key in open pos.	A1-A2-A3	3,4	Optional	OPEN	Different Ronis keys	OPEN
	RHL-D Lock with key in open and closed position	A1-A2	3,4	Optional	OPEN-CLOSED	Different Ronis keys	OPEN/CLOSED
Front for Lever Operating Mechanism	Padlock in open position	A3	3,4	Standard	OPEN	padlocks-max 3 padlocks Ø stem 6mm (not supplied)	-
	Compartment door lock	A3	3,4	Standard	CLOSED	Door lock	-
	RHL-D Lock with key in open pos.	A3	3,4	Optional	OPEN	Different Ronis keys	OPEN
	RHL-S Lock with key in open pos.	A3	3,4	Optional	OPEN	Same Ronis keys	OPEN

(1) Function can be completely excluded by the Customer during assembly of the handle [A1 and A2].

Accessories

Mechanical accessories

Ordering codes locks

Padlocks for lever operating mechanism of the circuit-breaker

1SDA...R1	
A1-A2	
PLL - Padlocks removable in open position	066259
PLL - Padlocks fixed in open position	066171
PLL - Padlocks fixed in open and closed position	066172

Key lock on Handle and front for lever operating mechanism

1SDA...R1		
	A1-A2	A3
RHL-D Lock in open position, different keys	066173	054939
RHL-S Lock in open position, same keys type A	066174	054940
RHL-S Lock in open position, same keys type B	066175	054941
RHL-S Lock in open position, same keys type C	066176	054942
RHL-S Lock in open position, same keys type D	066177	054943
RHL-D Lock in open/closed position different keys	066178	



Circuit-breaker with fixed padlock in open position



Circuit-breaker with fixed padlock in open and closed position



Key lock for direct handle

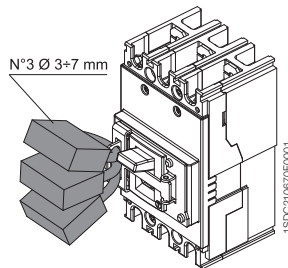

Fixed padlock in open/closed position

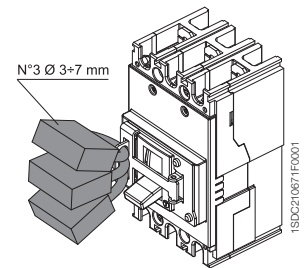

Fixed padlock in open/closed position



Key lock for transmitted handle

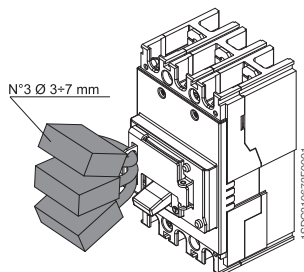

Fixed padlock in open position

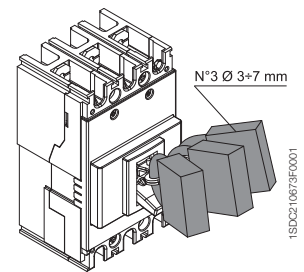

Removable padlock in open position



Key lock for front for locks



Bracket for DIN rail

Bracket for fixing on DIN rail

The bracket, applied on the back of the circuit-breakers, allows installation on a standardised DIN EN 50022 rail so as to simplify mounting in standard switchboards.

The bracket for fixing on DIN rail can be used with all the circuit-breakers in the SACE FORMULA family, with the exception of A3:

- A1 in 1p, 2p, 3p, 4p version;
- A2 in 1p, 2p, 3p, 4p version.

Ordering codes bracket for fixing on DIN rail

Bracket for fixing on DIN rail

	1SDA...R1
	A1-A2
Bracket for 1p, 2p, 3p and 4p	066180

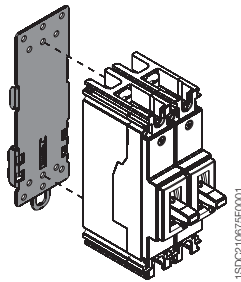

Bracket for DIN rail for 1p circuit-breaker

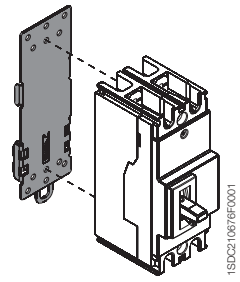

Bracket for DIN rail for 2p circuit-breaker

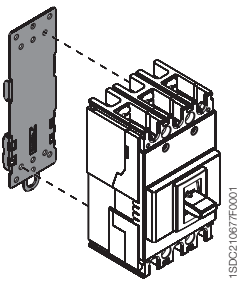

Bracket for DIN rail for 3p circuit-breaker

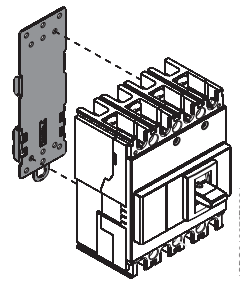

Bracket for DIN rail for 4p circuit-breaker

Accessories

Electrical accessories



Cabled service release
SOR-C and UVR-C

Service releases

The cabled shunt opening release SOR-C allows circuit-breaker opening by means of a non-permanent electrical control. Operation of the release is guaranteed for a voltage between 70% and 110% of the power supply rated voltage value U_n , in both alternating and direct current. It is fitted with an integrated limit contact for cutting off the power supply. The SOR-C mechanical life is 10% of the corresponding circuit-breaker.

The cabled undervoltage release UVR-C ensures circuit-breaker opening for lack/lowering of the release power supply voltage. Opening is guaranteed when the voltage is between 70% and 35% of U_n as specified in the Standard. After tripping, the circuit-breaker can be closed again starting from a voltage higher than 85% of U_n . With the undervoltage release de-energised, it is impossible to close the circuit-breaker and/or the main contacts. The UVR-C mechanical life is 10% of the corresponding circuit-breaker.

The service releases SOR-C and UVR-C for A1, A2 and A3, which can be mounted as an alternative between each other, are only available in the cabled version (20 AWG cable section/0.5mm²), with free cables 1 m long. For A1 and A2, snap-on assembly is carried out in the special slot of the circuit-breaker without using any screws. In the following circuit-breakers:

- two-pole (A1, A2), the SOR-C or UVR-C can be mounted as an alternative in the right-hand slot;
- three-pole (A1 A2 A3), the SOR-C or UVR-C can be mounted as an alternative in the left-hand slot;
- four-pole (A1,A2,A3), the SOR-C or UVR-C can be housed as an alternative, in the slot of the third pole.

SOR-C – Electrical characteristics

Versions	Absorbed power on inrush			
	SOR-C A1 - A2		SOR-C A3	
	AC [VA]	DC [W]	AC [VA]	DC [W]
12 VDC		50		150
24...30 VAC/DC	50...65	50...65	130...180	130...180
48...60 VAC/DC	60	60	130...180	130...180
110...127 VAC - 110...125 VDC	50	50	120...150	120...150
220...240 VAC - 220...250 VDC	50...60	50...60	100...150	100...150
380...440 VAC	55		130...180	
480...525 VAC*	55		150	

* A3 up to 500 VAC

UVR-C – Electrical characteristics

Versions	Absorbed power during normal operation			
	UVR-C A1 - A2		UVR-C A3	
	AC [VA]	DC [W]	AC [VA]	DC [W]
24...30 VAC/DC	1.5	1.5	3	3
48 VAC/DC	1	1	3	3
60 VAC/DC	1	1	3	3
110...127 VAC - 110...125 VDC	2	2	3	3
220...240 VAC - 220...250 VDC	2.5	2.5	3	3
380...440 VAC	3		3	
480...525 VAC*	4		3	

* A3 up to 500 VAC

Ordering codes service releases

Shunt opening release – SOR-C

Cabled version	1SDA...R1	
	A1-A2	A3
SOR-C 12 VDC	066133	054869
SOR-C 24...30 VAC/DC	066134	054870
SOR-C 48...60 VAC/DC	066135	054871
SOR-C 110...127 VAC - 110...125 VDC	066136	054872
SOR-C 220...240 VAC - 220...250 VDC	066137	054873
SOR-C 380...440 VAC	066138	054874
SOR-C 480...525 VAC*	066141	054875

* A3 up to 500 VAC

Undervoltage release – UVR-C

Cabled version	1SDA...R1	
	A1-A2	A3
UVR-C 24...30 VAC/DC	066143	054887
UVR-C 48 VAC/DC	066144	054888
UVR-C 60 VAC/DC	067114	054889
UVR-C 110...127 VAC - 110...125 VDC	066145	054890
UVR-C 220...240 VAC - 220...250 VDC	066146	054891
UVR-C 380...440 VAC	066147	054892
UVR-C 480...525 VAC*	066148	054893

* A3 up to 500 VAC

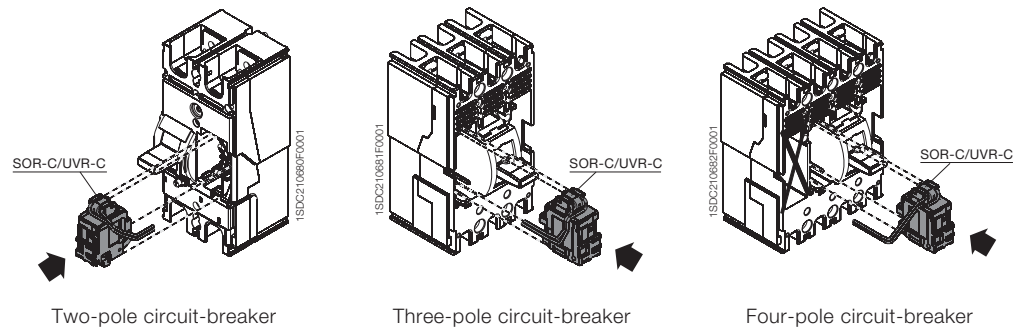

Accessories

Electrical accessories



Cabled auxiliary contact

Auxiliary contacts for the electrical signals

The auxiliary contacts allow information about the state of the circuit-breaker to be taken outside. The signals available are as follows:

- open/closed: signalling the position of the circuit-breaker power contacts (Q);
- release trip: signalling circuit-breaker opening due to tripping of the thermomagnetic or electronic trip unit (due to overload or short-circuit), of the opening of undervoltage release SOR-C or UVR-C, or by activation of the test pushbutton (SY).

Auxiliary contacts AUX-C Q, AUX-C SY

Installation of the auxiliary contacts for A1 and A2 (at 250 VAC/DC) snap-on in the special slot of the circuit-breaker without the use of any screws. All the auxiliary contacts are supplied in the cabled version (20 AWG cable section/0.5mm²), with loose cables 1 m long. The combinations of auxiliary contacts available, vary according to the circuit-breaker. In particular, in the following circuit-breakers:

- two-pole, the 1Q+1SY (for A1) and 2Q+1SY (for A2) combination is available;
- three-pole and four-pole, the 1Q+1SY and 2Q+1SY (for A1 and A2) and 1Q+1SY or 3Q+1SY (for A3) combination is available.

An AUX-C contact is also available as spare part and it can be used as Q or SY according to the slot of the circuit-breaker in which it is inseted.

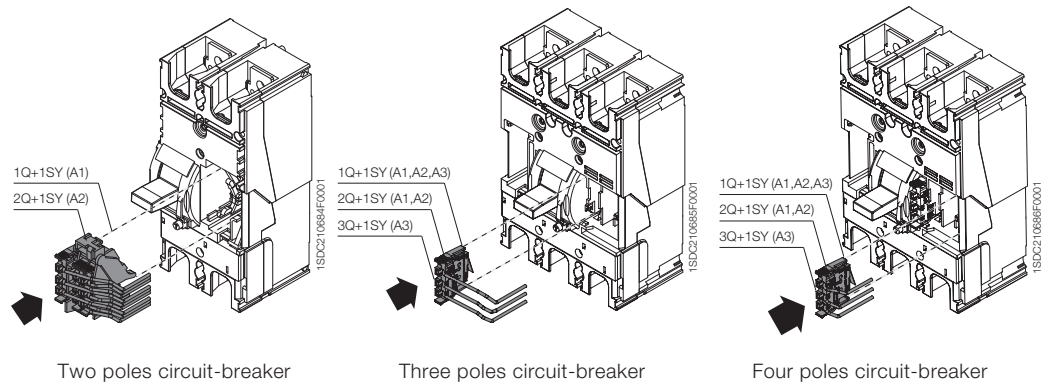

AUX-C – Electrical characteristics

Category of use ^(G2.13) [IEC 60947-5-1]	Voltage	Current
	[V]	[A]
AC-12/AC-13/AC-14	125	6
AC-15	125	5
AC-12/AC-13/AC-14	250	6
AC-15	250	4
DC-12	110	0,5
DC-14	110	0,05
DC-12	250	0,3
DC-14	250	0,03

Ordering codes auxiliary contacts for the electrical signal

Auxiliary contacts – AUX-C

	1SDA...R1				
	A1		A2		A3
	2 poles	3-4 poles	2 poles	3-4 poles	3-4 poles
Cabled version (numbered cables)					
AUX-C 1Q + 1SY 250 VAC/DC	066151	066149		066149	054910
AUX-C 2Q + 1SY 250 VAC/DC		066150	066152	066150	
AUX-C 3Q + 1SY 250 VAC/DC					054911
Cabled version (spare parts)					
AUX-C	066258	066258	066258	066258	



Early auxiliary contact

1SDC210687F0001

Early auxiliary contacts AUE-C

The cabled early auxiliary contacts (AUE-C) are normally open contacts, early in relation to closing, which allow the undervoltage release to be supplied in advance in relation to closing of the main contacts in conformity with the IEC 60204-1, VDE 0113 Standards.

It is possible to insert up to two early auxiliary contacts on closing inside the direct and transmitted rotary handle operating mechanism for circuit-breakers A1, A2, A3 in the three-pole and four-pole version. The contacts, supplied in the cabled version, with cables 1 m long (20 AWG cable section/0.5mm²), must be ordered in combination with an undervoltage release.

AUE -C – Electrical characteristics

Voltage [V]	Current [A]	
	AC	DC
125 DC	-	0.5
250 AC/DC	12	0.3
400 AC	3	-

Ordering codes early auxiliary contacts

Early auxiliary contacts – AUE-C

	1SDA...R1	
	A1-A2	A3
AUE-C	066153	054925

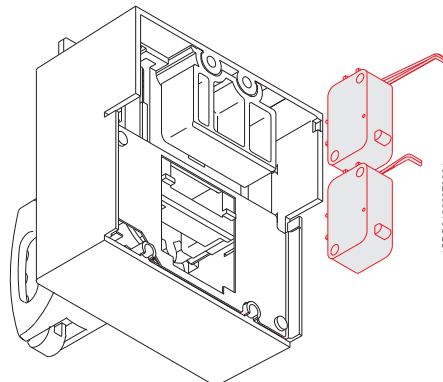

1SDC210689F0001

Accessories

FORMULA Link

FORMULA Link is a component of a power distribution system which divides the main power supply over different users. The FORMULA Link is characterised on the supply side by a main circuit-breaker which protects the whole distribution system, and on the load side by smaller sized circuit-breakers, dedicated to the individual users. All the copper components are tin plated. FORMULA Link has been realized in accordance with IEC 60439 Standard.

Looses components

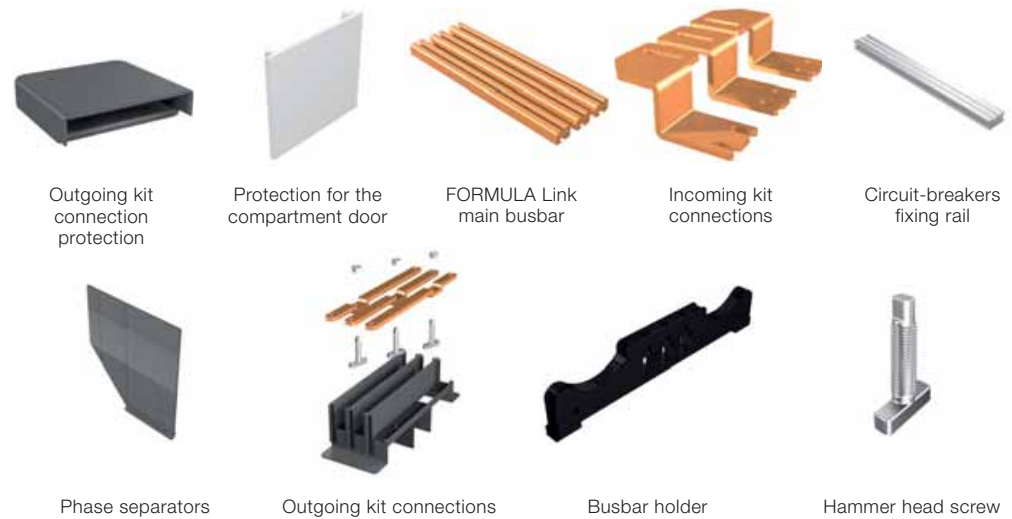

FORMULA Link Systems

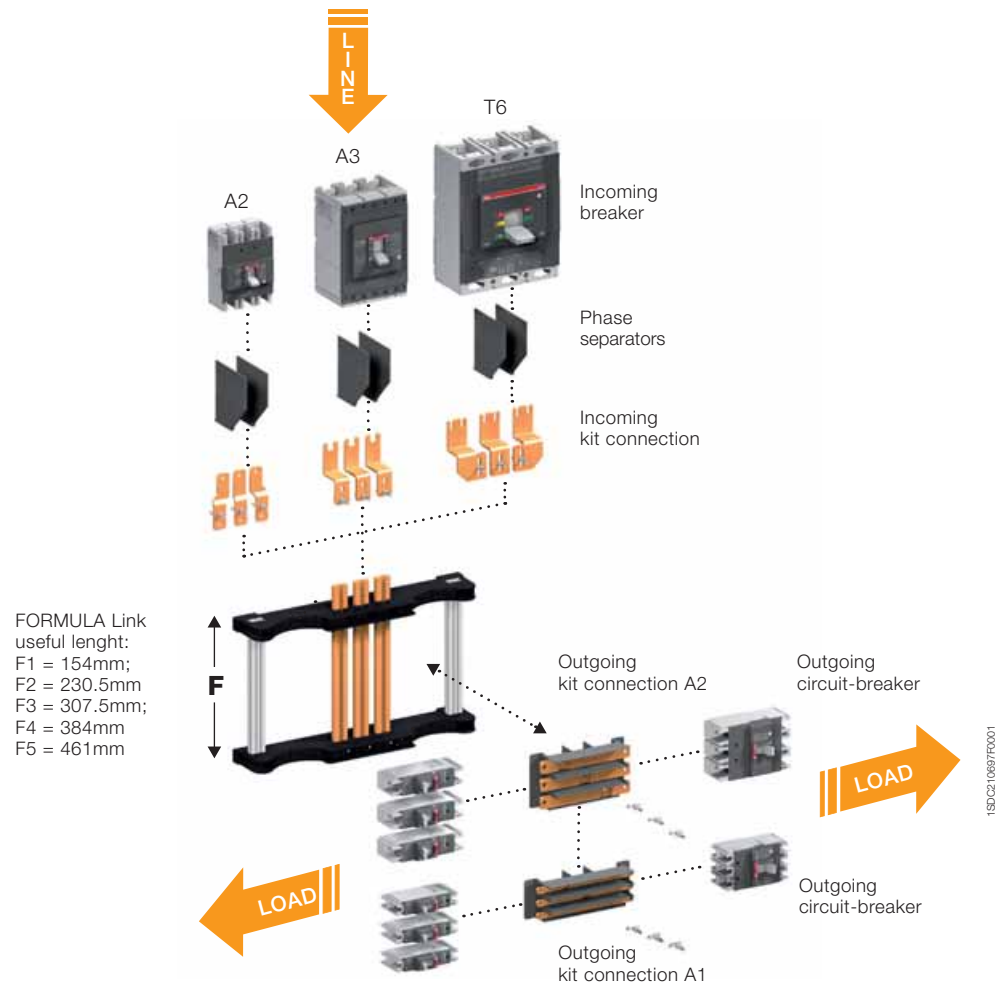

Three different frames of FORMULA Links are available according to the incoming current of the system:

- 250A FORMULA Link, usable with SACE FORMULA A2 circuit-breaker as incoming breaker;
- 400A FORMULA Link, usable with SACE FORMULA A3 circuit-breaker as incoming breaker;
- 630/800A FORMULA Link, usable with SACE Tmax T6 circuit breaker up 800A as incoming breaker.

FORMULA Link - Mechanical characteristics

FORMULA Link frame	[A]	250					400					630/800				
Length		F1	F2	F3	F4	F5	F1	F2	F3	F4	F5	F1	F2	F3	F4	F5
Number of outgoing circuit-breaker (SACE FORMULA A1)	1p	12	18	24	30	36	12	18	24	30	36	12	18	24	30	36
	2p	6	8	12	14	18	6	8	12	14	18	6	8	12	14	18
	3p	4	6	8	10	12	4	6	8	10	12	4	6	8	10	12

FORMULA Link - Electrical characteristics

FORMULA Link frame	[A]	250			400			630/800		
Incoming Breaker		A2			A3			T6		
Outgoing Breaker		A1			A1-A2			A1-A2		
Rated Operational Voltage 50/60 Hz	[V]	550 AC			550 AC			550 AC		
Rated Insulation Voltage	[V]	690 AC			690 AC			690 AC		
Rated Short Time Withstand Current (1s)	[kA]	30			40			40		



Incoming kit connections for SACE FORMULA A2



Incoming kit connections for SACE FORMULA A3



Incoming kit connections for SACE Tmax T6

To connect the main circuit-breaker to the FORMULA Link, it is necessary to use the special incoming kit connections.

The connection kits change in relation to the incoming breaker chosen. They are available:

- for SACE FORMULA A2 circuit-breaker;
- for SACE FORMULA A3 circuit-breaker;
- for SACE Tmax T6 circuit-breaker;

It's possible to connect the cables directly to the FORMULA Link using the dedicated incoming kit connection for lugs (lugs not supplied).

Either A1 or A2 SACE FORMULA circuit-breakers in the single-pole, two-pole and three-pole version can be used for protection of the individual users. The outgoing circuit-breakers are connected onto the main FORMULA Link with connection kits composed of copper connections and thermoplastic bases which assure the alignment and insulation between the phases. Two outgoing kit connections are available:

- kit for SACE FORMULA A1 circuit-breakers;
- kit for SACE FORMULA A2 circuit-breakers.

Having six connection terminals, each kit allows connection of two three-pole or of six single-pole circuit-breakers.

Accessories

FORMULA Link

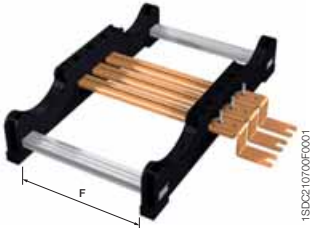

FORMULA Link

1SDC210700F0001

Each FORMULA Link frame is available in five different useful length for the assembling of the outgoing kit connections:

- F1: 154mm;
- F2: 230.5mm;
- F3: 307.5mm;
- F4: 384mm;
- F5: 461mm.

The length of the FORMULA Link is connected to the number and type of circuit-breakers (A1 or A2, in single-pole, two-pole or three-pole versions) that have to be installed.

In the table below all the possible combinations of three-pole outgoing circuit-breakers are shown. Starting from the number of outgoing ways required, it is possible to obtain the number of connection kit and the length of the FORMULA Link needed.

Outgoing Ways		Number of A1 Outgoing kit connections	Number of A2 Outgoing kit connections	Frame length
Number A1 3p	Number A2 3p			
4	0	2	0	F1 [154 mm]
0	2	0	1	
6	0	3	0	F2 [230.5 mm]
2	2	1	1	
0	4	0	2	
8	0	4	0	F3 [307.5 mm]
4	2	2	1	
2	4	1	2	
10	0	5	0	F4 [384 mm]
6	2	3	1	
4	4	2	2	
0	6	0	3	
12	0	6	0	F5 [461 mm]
8	2	4	1	
6	4	3	2	
2	6	1	3	
0	8	0	4	

Ordering code for FORMULA Link

During the ordering stage, it is necessary to specify the codes of the following components which are already preassembled:

- **incoming kit connections** according to the incoming current;
- **outgoing kit connections** according to the type and number of outgoing circuit-breakers (the code of the outgoing kit connection includes the base made of thermoplastic material, copper connections and hammer screws for fixing and six outgoing kit connection protections);
- **FORMULA Link frame** according to the length needed and the incoming current (the code includes: 3 main busbars, 2 busbars holder supports, 2 circuit-breakers fixing rails, screws, all ready to be assembled).

Incoming kit connections

	1SDA...R1
Incoming kit connections A2	066822
Incoming kit connections A3	066823
Incoming kit connections T6	066824
Incoming kit connections FORMULA Link 630/800 for lugs 630/800A	068744
Incoming kit connections FORMULA Link 250 for lugs 250A	068839
Incoming kit connections FORMULA Link 400 for lugs 400A	068840

Outgoing kit connections

	1SDA...R1
Outgoing kit connections A1	066841
Outgoing kit connections A2	066842

FORMULA Link frame (ready to be assembled)

	1SDA...R1				
	F1	F2	F3	F4	F5
FORMULA Link 250A for A1	066825	066827	066828	066829	066830
FORMULA Link 400A for A1-A2	066831	066832	066833	066834	066835
FORMULA Link 630/800A for A1-A2	066836	066837	066838	066839	066840

Loose components

	1SDA...R1
Aluminium fixing bar L=1.2m	066847
Busbar holder	066843
Busbar 250A L=1.2m	066844
Busbar 400A L=1.2m	066845
Busbar 630/800A L=1.2m	066846
Hammer Head Screws (15 pieces)	066848
Phase separators kit (2 pieces)	067538
Protection for compartment door (2 pieces) L=465mm	067539
Kit protection A1 (15 pieces)	068740
Kit protection A2 (15 pieces)	068741

Accessories

FORMULA Link



Examples of order

EXAMPLE 1

Composition to be made

- Incoming breaker: A3 400A;
- Outgoing ways: 4 A1 3p.

Ordering code:

- 1SDA066823R1 (Quantity 1) - Incoming kit connections A3 400A;
- 1SDA066841R1 (Quantity 2) - Outgoing kit connections A1: each kit to be used for 2 SACE FORMULA A1 3 poles;
- 1SDA066831R1 (Quantity 1) - Frame 400A, with a useful length F1=154 mm.

Step 1: Selection of the incoming kit connections code.

Since as incoming breaker there is a 400A SACE FORMULA circuit-breaker, it is necessary to order the proper kit of terminal useful to connect the FORMULA Link and the incoming breaker.

Incoming kit connection

	1SDA...R1
Incoming kit connection A2	066822
Incoming kit connection A3	066823
Incoming kit connection T6	066824
Incoming kit connections FORMULA Link 630/800 for lugs 630/800A	068744
Incoming kit connections FORMULA Link 250 for lugs 250A	068839
Incoming kit connections FORMULA Link 400 for lugs 400A	068840

Step 2: Definition of the number of the necessary outgoing kit connection, according to the number of outgoing ways and defining length of the frame. To connect 4 SACE FORMULA A1 3 poles circuit-breakers as outgoing ways, it is necessary to order two "outgoing kit connections A1" and the frame 400A with useful length "F1".

Outgoing Ways		Number of A1 Outgoing kit connections	Number of A2 Outgoing kit connections	Frame length
Number A1 3p	Number A2 3p			
4	0	2	0	F1 [154 mm]
0	2	0	1	
6	0	3	0	F2 [230.5 mm]
2	2	1	1	
0	4	0	2	
8	0	4	0	F3 [307.5 mm]
4	2	2	1	
2	4	1	2	
10	0	5	0	
6	2	3	1	F4 [384 mm]
4	4	2	2	
0	6	0	3	
12	0	6	0	
8	2	4	1	F5 [461 mm]
6	4	3	2	
2	6	1	3	
0	8	0	4	

Outgoing kit connections

	1SDA...R1
Outgoing kit connections A1	066841
Outgoing kit connections A2	066842

FORMULA Link frame

	1SDA...R1				
	F1	F2	F3	F4	F5
FORMULA Link ensemble 250A for A1	066825	066827	066828	066829	066830
FORMULA Link ensemble 400A for A1-A2	066831	066832	066833	066834	066835
FORMULA Link ensemble 630/800A for A1-A2	066836	066837	066838	066839	066840



Examples of order

EXAMPLE 2

Composition to be made

- Incoming breaker: Tmax T6 630A;
- Outgoing ways: 4 A1 3p + 2 A2 3p.

Ordering code:

- 1SDA066824R1 (Quantity 1) - Incoming kit connections Tmax T6 630A;
- 1SDA066841R1 (Quantity 2) - Outgoing kit connections A1: each kit to be used for 2 SACE FORMULA A1 3 poles;
- 1SDA066842R1 (Quantity 1) - Outgoing kit connections A2: each kit to be used for 2 SACE FORMULA A2 3 poles;
- 1SDA066838R1 (Quantity 1) - Frame 630A, with a useful length F3=307.5 mm.

Step 1: Selection of the incoming kit connections code.

Since as incoming breaker there is a 630A Tmax T6 circuit-breaker, it is necessary to order the proper kit of terminal useful to connect the FORMULA Link and the incoming breaker.

Incoming kit connection

	1SDA...R1
Incoming kit connection A2	066822
Incoming kit connection A3	066823
Incoming kit connection T6	066824
Incoming kit connections FORMULA Link 630/800 for lugs 630/800A	068744
Incoming kit connections FORMULA Link 250 for lugs 250A	068839
Incoming kit connections FORMULA Link 400 for lugs 400A	068840

Step 2: Definition of the number of the necessary outgoing kit connection, according to the number of outgoing ways and defining length of the frame. To connect 4 SACE FORMULA A2 3 poles circuit-breakers as outgoing ways, it is necessary to order two "outgoing kit connections A1" and the frame 630A with useful length "F3".

Outgoing Ways		Number of A1 Outgoing kit connections	Number of A2 Outgoing kit connections	Frame length
Number A1 3p	Number A2 3p			
4	0	2	0	F1 [154 mm]
0	2	0	1	
6	0	3	0	F2 [230.5 mm]
2	2	1	1	
0	4	0	2	
8	0	4	0	F3 [307.5 mm]
4	2	2	1	
2	4	1	2	
10	0	5	0	F4 [384 mm]
6	2	3	1	
4	4	2	2	
0	6	0	3	
12	0	6	0	F5 [461 mm]
8	2	4	1	
6	4	3	2	
2	6	1	3	
0	8	0	4	

Outgoing kit connections

	1SDA...R1
Outgoing kit connections A1	066841
Outgoing kit connections A2	066842

FORMULA Link frame

	1SDA...R1				
	F1	F2	F3	F4	F5
FORMULA Link structure 250A for A1	066825	066827	066828	066829	066830
FORMULA Link structure 400A for A1-A2	066831	066832	066833	066834	066835
FORMULA Link structure 630/800A for A1-A2	066836	066837	066838	066839	066840



Content

Examples of curve readings	4/2
Temperature performance	4/3
Trip curves for power distribution	
Trip curves with thermomagnetic and electronic trip units	4/5
Specific let-through energy curves	
230V	4/5
415V - 440V	4/6
500V - 550V	4/7
Limitations curves	
230V	4/8
415V - 440V	4/9
500V - 550V	4/10
Technical Information	
Dissipated powers	4/13
Coordination tables (back-up)	
Notes for use	4/14
MCCB-MCB (415V)	4/15
MCCB-MCCB (415V)	4/16

Examples of curve reading

Example 1 – A2 250

Trip curves for power distribution (thermomagnetic trip unit)

Let us consider an A2 250In = 200A circuit-breaker. It can be noted that, on the basis of the conditions under which the overload occurs, i.e. with the circuit-breaker with thermal running or not, the time trip protection varies considerably. For example for overload current $2 \times I_n$, the trip time is between 65.2s and 200s for cold trip and between 9.9s and 65.2s for hot trip. For fault current values higher than 2000A the circuit-breaker trips instantaneously with the magnetic protection I3.

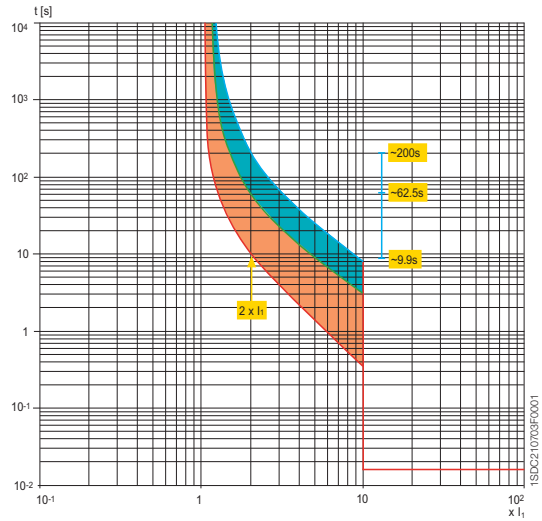

Example 2 – A1 125

Specific let-through energy curve

The following figure gives an example of reading the graph of the specific let-through energy curve of the A1 125 In=125A circuit-breaker at a voltage of 400V/415V. The prospective symmetrical short-circuit current is indicated on the abscissas, whereas the value of the specific let-through energy expressed in $A^2 s$ is shown on the ordinates. In correspondence with a short-circuit current of 20kA, the circuit-breaker lets through a value of $I^2 t$ equal to $0.70 \times 10^6 A^2 s$.

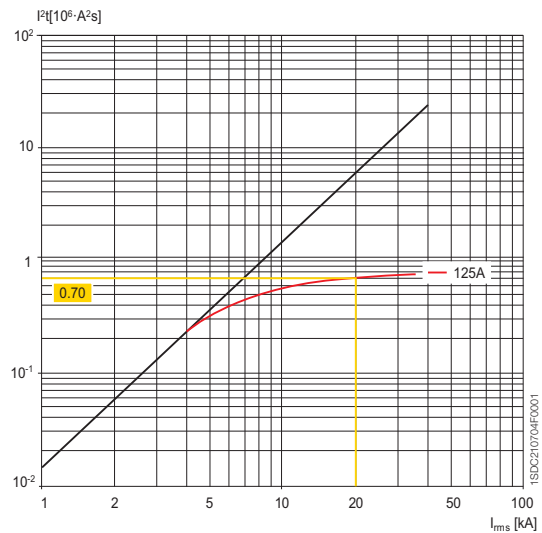

Example 3 – A1 125

Limitation curves

The following figure gives the trend of the limiting curve of the A2 125 In = 125A circuit-breaker. The r.m.s. value of the prospective symmetrical short-circuit current is given on the diagram abscissas, whereas the peak value of the short-circuit current is indicated on the ordinates. The limiting effect can be assessed by comparing, at the same value of symmetrical short-circuit current, the peak value corresponding to the prospective short-circuit current (curve A) with the peak value limited (curve B). The A1 125 circuit-breaker with thermomagnetic trip unit In = 125A at a voltage of 400V/415V, for a fault current of 20kA limits the prospective short-circuit peak current to 15kA, with a reduction compared with the peak value of the prospective short-circuit current of 25kA.

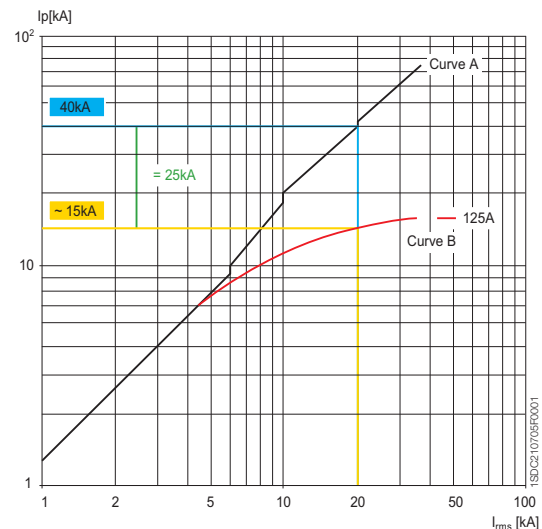

Temperature performances

All the SACE FORMULA circuit-breakers can be used under the following environmental conditions:

- -25 °C +70 °C: range of temperature where the circuit-breaker is installed;
- -40 °C +70 °C: range of temperature where the circuit-breaker is stored.

The SACE FORMULA circuit breaker has been designed to hold 100% In at 50°C without tripping in normal condition (except for A1 125A).

To determinate tripping time using time/current curves, use I t°C values indicated in the tables below.

SACE FORMULA A1 circuit-breaker with termomagnetic trip unit TMF

In [A]	10°C	20°C	30°C	40°C	50°C	60°C	70°C
5	6.5	6.1	5.8	5.4	5	4.8	4.5
10	12.9	12.2	11.5	10.8	10	9.6	9.0
15	19.4	18.4	17.3	16.2	15	14.4	13.5
16	20.7	19.6	18.5	17.3	16	15.3	14.4
20	24.6	23.5	22.4	21.2	20	19.2	18.0
25	29.2	28.2	27.2	25.9	25	24.0	22.5
30	36.8	35.3	33.6	31.8	30	28.8	27.0
32	39.3	37.6	35.9	33.9	32	30.7	28.8
40	46.7	45.2	43.5	41.5	40	38.3	36.0
50	58.3	56.5	54.3	51.9	50	47.9	45.0
60	70.0	67.8	65.2	62.2	60	57.5	54.0
63	73.5	71.2	68.5	65.4	63	60.4	56.7
70	81.7	79.1	76.1	72.6	70	67.1	63.0
80	91.0	88.5	85.6	82.1	80	76.7	72.0
90	102.4	99.6	96.3	92.4	90	86.3	81.0
100	116.7	113.0	108.7	103.7	100	95.9	90.0
125	146.6	139.8	132.6	125.0	116.9	108.3	98.8

SACE FORMULA A2 circuit-breaker with termomagnetic trip unit TMF

In [A]	10°C	20°C	30°C	40°C	50°C	60°C	70°C
125	161	153	144	135	125	114	102
150	184	176	168	159	150	138	126
160	196	188	179	169	160	148	135
175	215	206	196	185	175	160	144
200	246	235	224	212	200	183	165
225	290	276	260	243	225	205	184
250	323	306	289	270	250	228	204

SACE FORMULA A3 circuit-breaker with termomagnetic trip unit TMF (special version 50°C)

In [A]	10°C	20°C	30°C	40°C	50°C	60°C	70°C
300	393	372	350	326	300	272	241
400	516	490	462	432	400	365	327

SACE FORMULA A3 circuit-breaker with termomagnetic trip unit TMF

In [A]	10°C	20°C	30°C	40°C	50°C	60°C	70°C
320	368	350	335	320	305	285	263
400	465	442	420	400	380	355	325
500	620	580	540	500	450	400	345

The circuit-breaker fitted with electronic trip units do not undergo any variations in performance as the temperature varies, but in the case of temperatures exceeding +40°C, the used rated current must be reduced to protect the copper parts of the circuit-breaker.

SACE FORMULA A3 circuit-breakers with electronic trip unit ELT LI

In [A]	35°C	40°C	45°C	50°C	55°C	60°C	65°C	70°C
630	630	630	630	580	555	529	502	478

Trip curves

Trip curves with thermomagnetic and electronic trip units

A1 125A - TMF

$I_n = 15 \div 70 \text{ A}$

$I_3 = 300\text{A}$ for $I_n < 25$

$I_3 = 10I_n$ for $I_n \geq 30\text{A}$

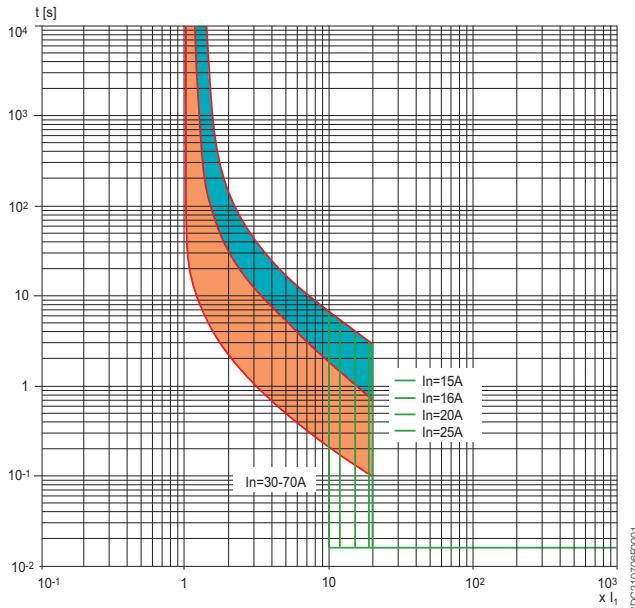

A1 125A - TMF

$I_n = 80 \div 100 \text{ A}$

$I_3 = 10I_n$

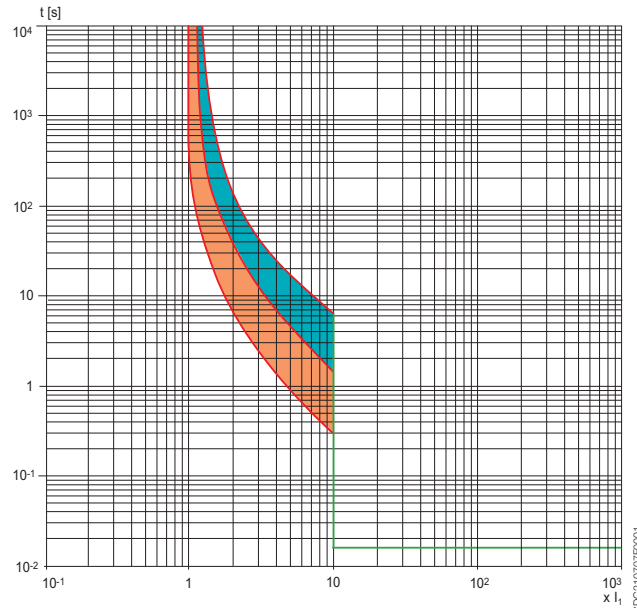

A1 125A - TMF

$I_n = 125 \text{ A}$

$I_3 = 10I_n$

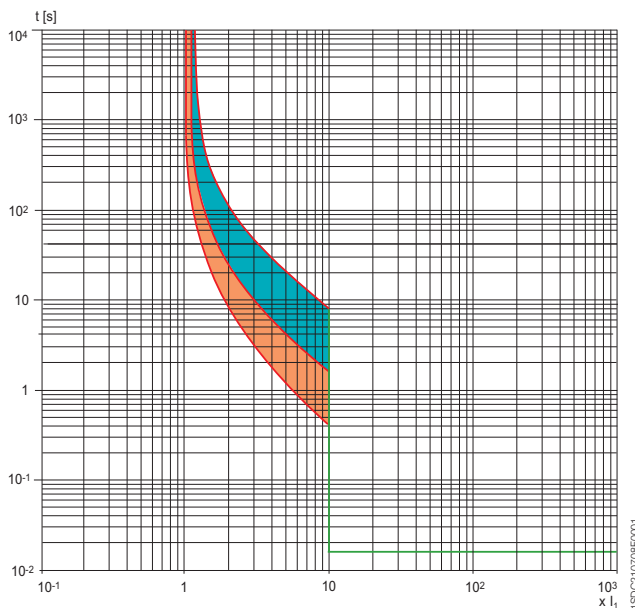

A2 250A - TMF

$I_n = 125 \div 250 \text{ A}$

$I_3 = 10I_n$

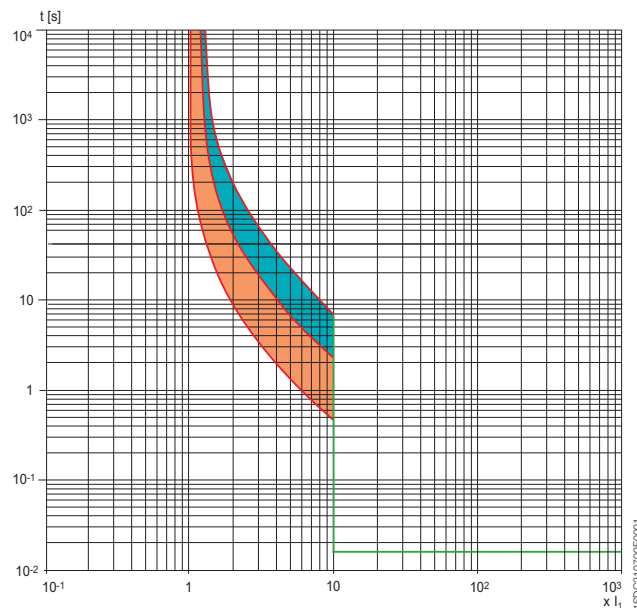

Trip curves

Trip curves with thermomagnetic and electronic trip units

A3 630A - TMF

$I_n=320\div500\text{ A}$

$I_3=10I_n$

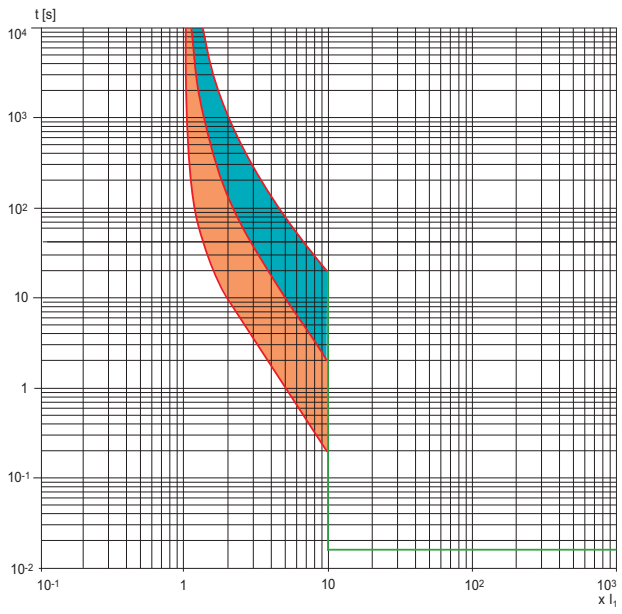

A3 630A - TMF

Special version 50°C

$I_n=300\div400\text{ A}$

$I_3=10I_n$

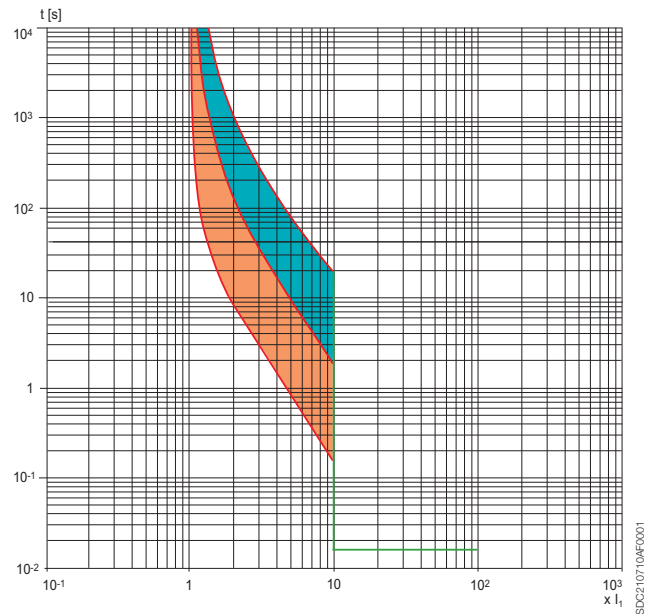

A3 630A - ELT LI

$I_3=10I_n$

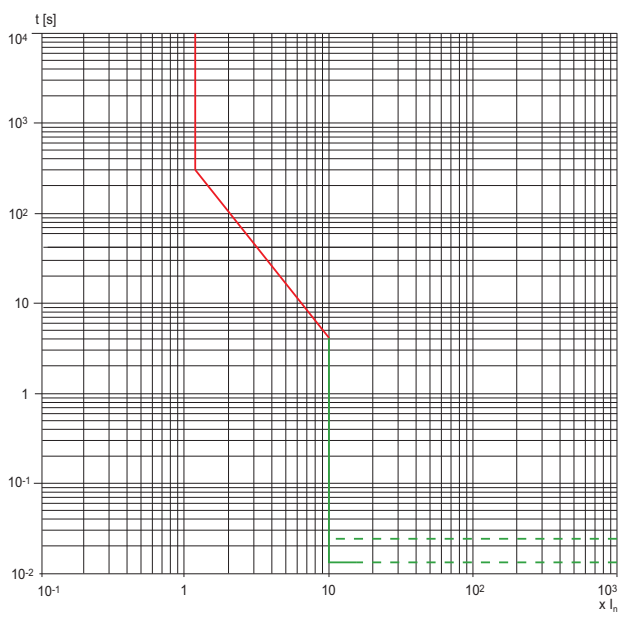

Specific let-through energy curves

A1 125A
230V

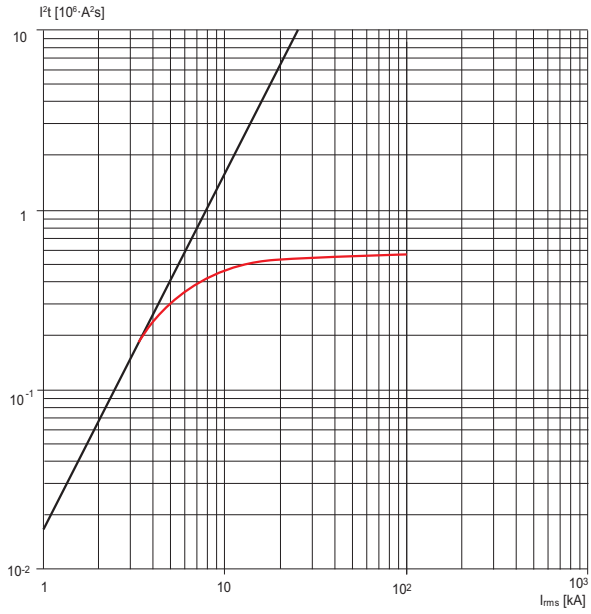

1SDC210712FC001

A2 250A
230V

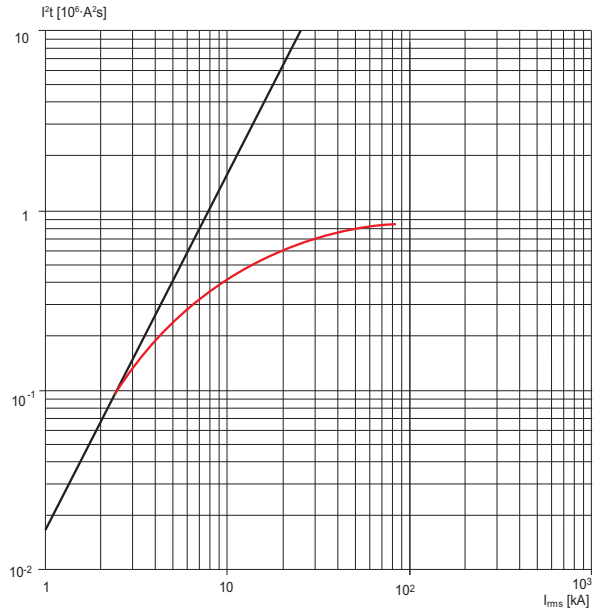

1SDC210713FC001

A3 630A
230V

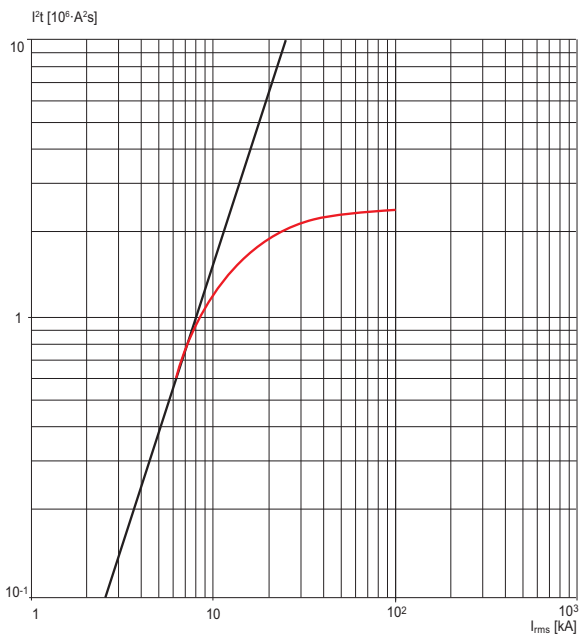

1SDC210714FC001

Specific let-through energy curves

A1 125A
415-440V

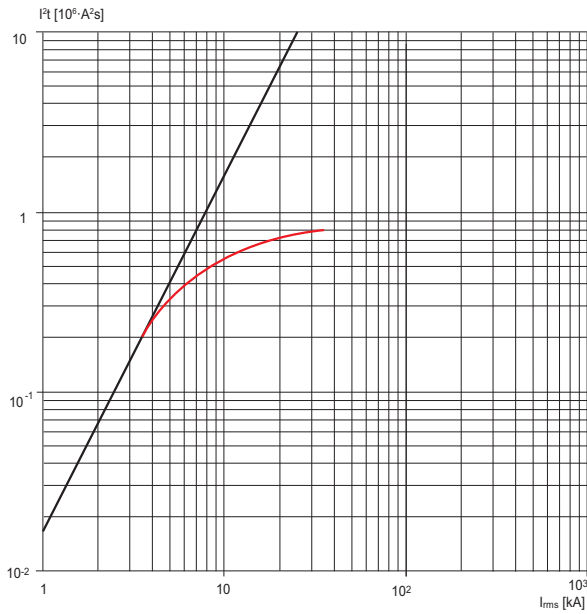

1SDC210716F0001

A2 250A
415-440V

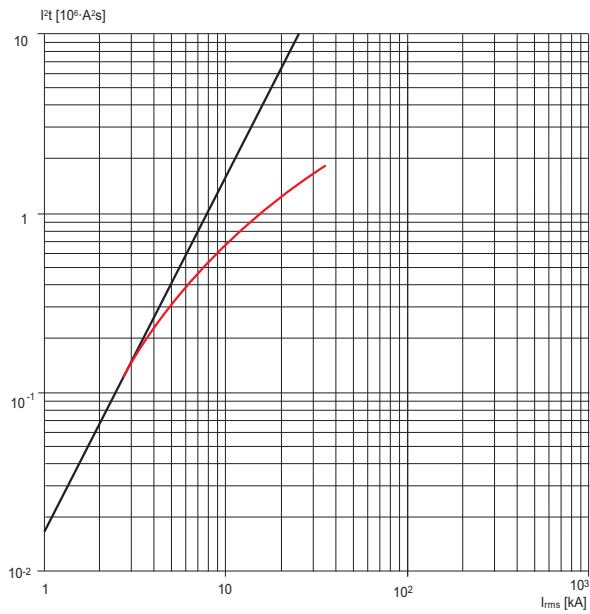

1SDC210716F0001

A3 630A
415-440V

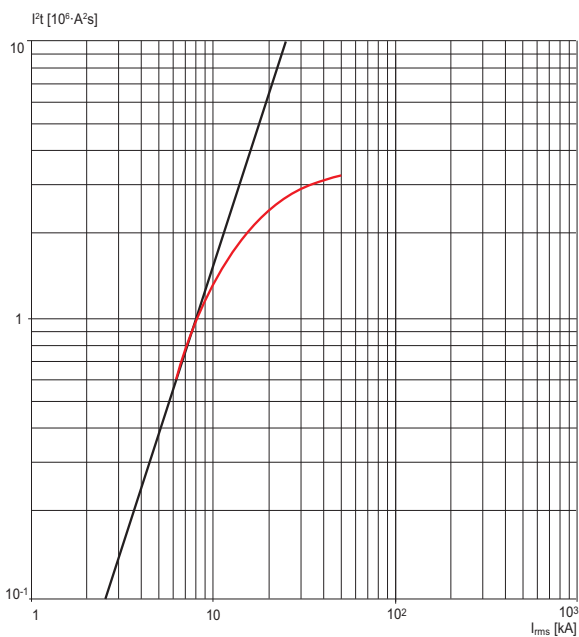

1SDC210716F0001

A1 125A 500-550V

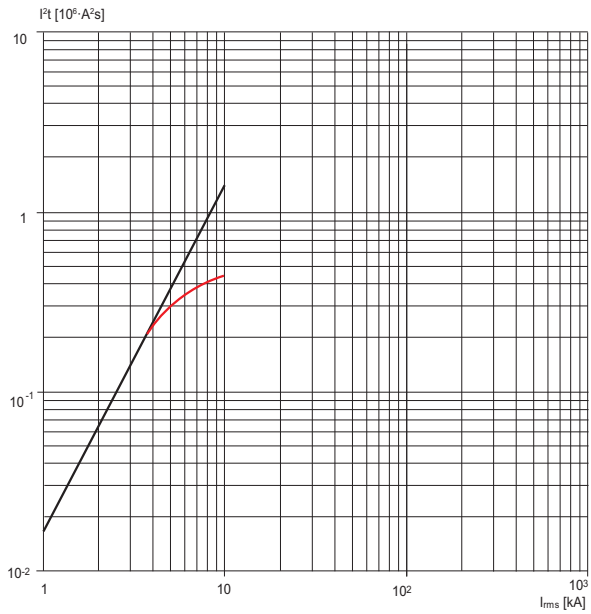

1SDC210719F0001

A2 250A 500-550V

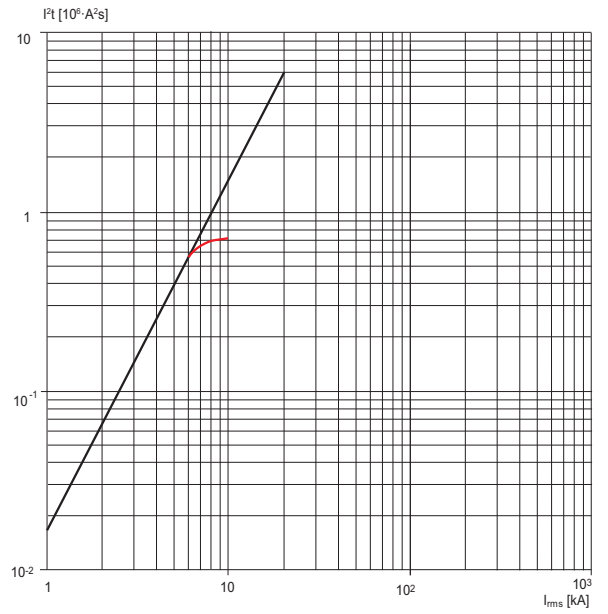

1SDC210719F0001

A3 630A 500-550V

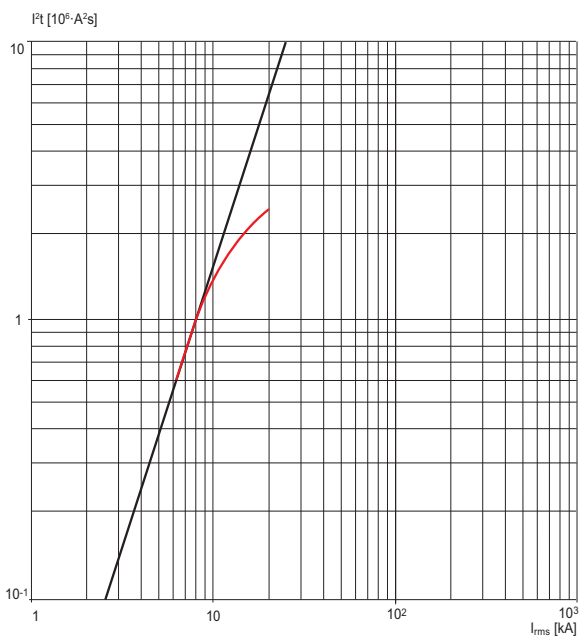

1SDC210720F0001

Limitation Curves

A1 125A
230V

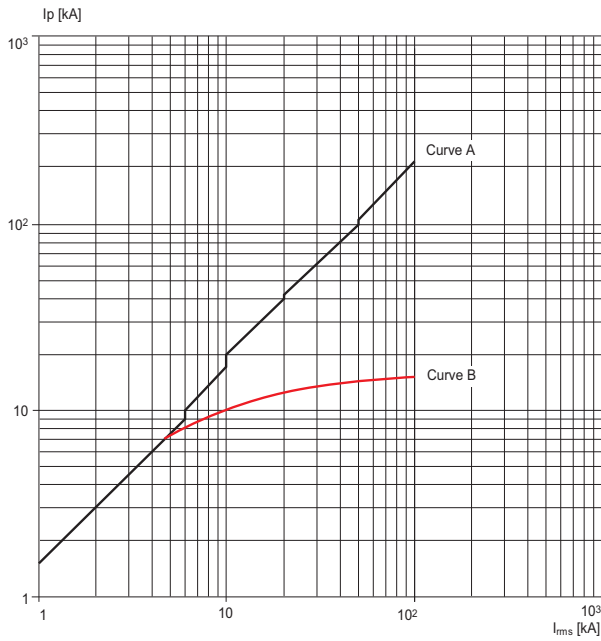

1SDC210722F0001

A2 250A
230V

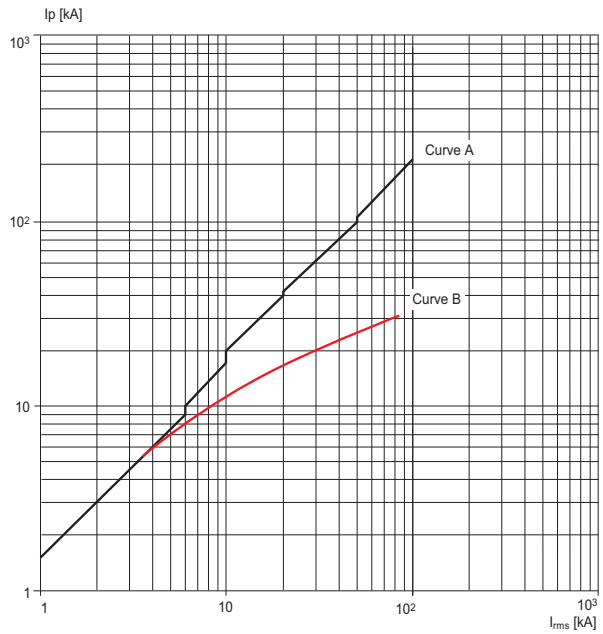

1SDC210722F0001

A3 630A
230V

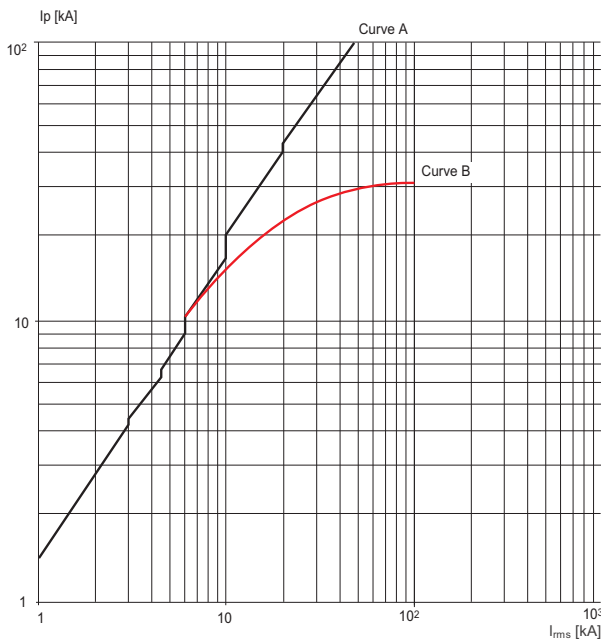

1SDC210722F0001

A1 125A 415-440V

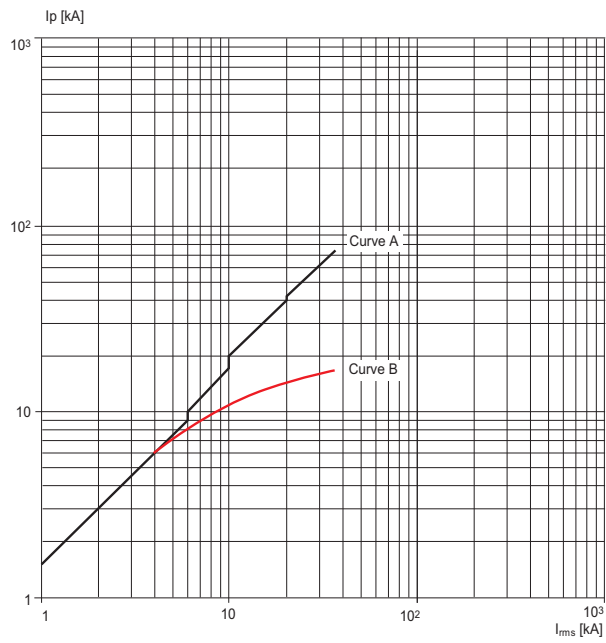

1SDC210724F0001

A2 250A 415-440V

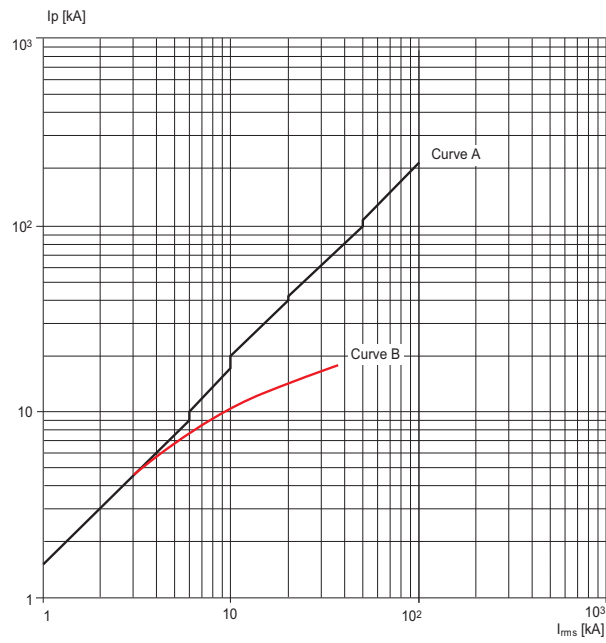

1SDC210724F0001

A3 630A 415-440V

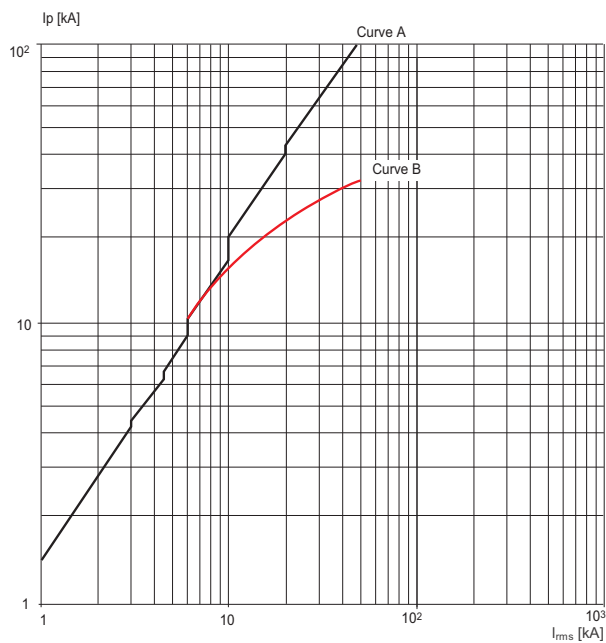

1SDC210726F0001

Limitation Curves

A1 125A
500-550V

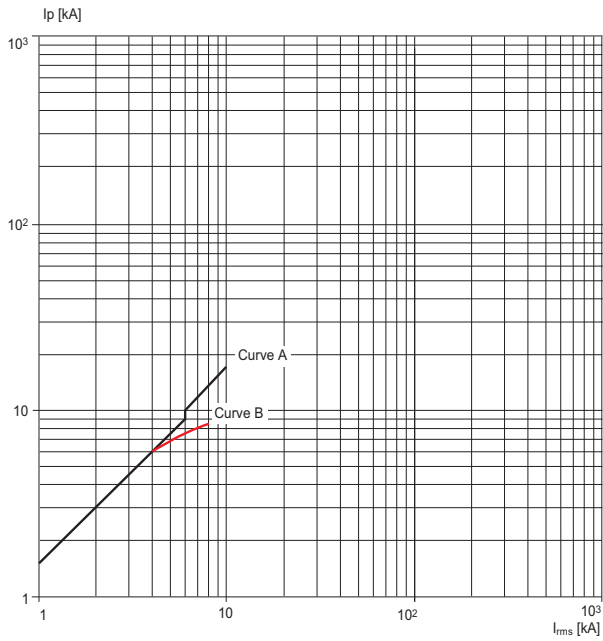

1SDC210729F0001

A2 250A
500-550V

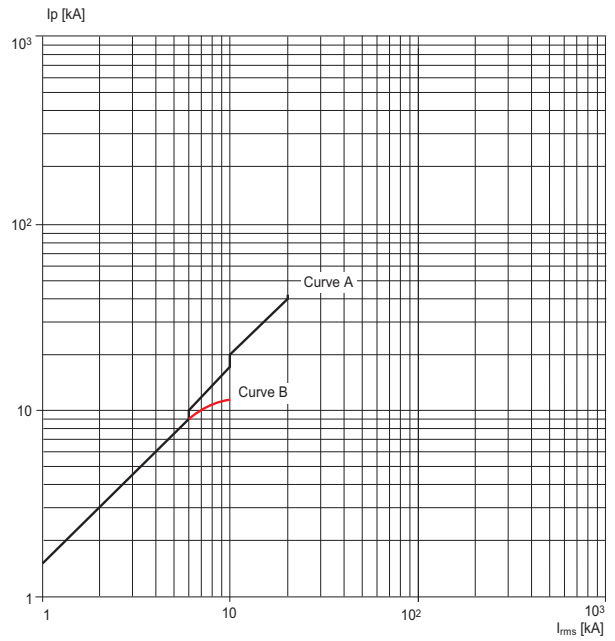

1SDC210729F0001

A3 630A
500-550V

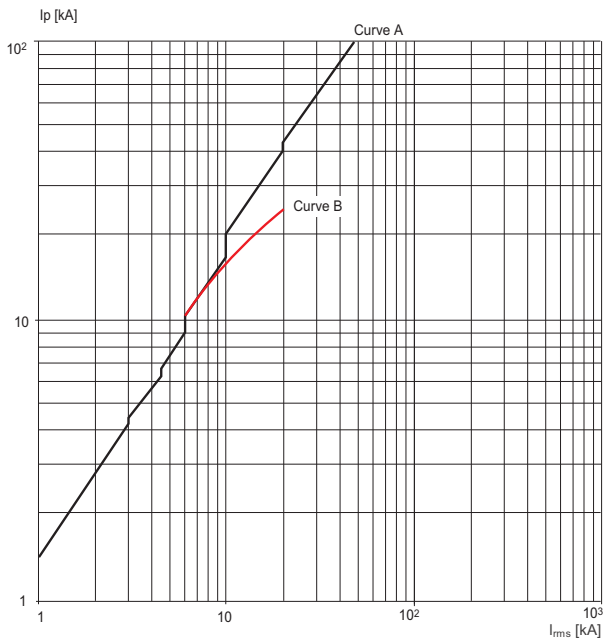

1SDC210729F0001

Technical information

Dissipated powers

For each circuit-breaker, the table gives the dissipated power values for a single pole circuit-breaker ^(G2.12).

The maximum total dissipated power of a two-pole, three-pole or four-pole circuit-breaker used at 50/60Hz is equal to the dissipated power for the single pole multiplied by the number of poles.

Power [W/pole]	In [A]	A1	A2	A3
TMF	15	2.5	-	-
	16	2.8	-	-
	20	3	-	-
	25	3	-	-
	30	4	-	-
	32	4	-	-
	40	4.5	-	-
	50	5.5	-	-
	60	6	-	-
	63	6	-	-
	70	8	-	-
	80	9	-	-
	90	7	-	-
	100	8	-	-
	125	11	7	-
	150	-	8	-
	160	-	9	-
175	-	10	-	
200	-	12	-	
225	-	14	-	
250	-	16	-	
320	-	-	13.6	
400	-	-	19.5	
500	-	-	28.8	
ELT LI	630	-	-	41

Coordination tables (back-up)

Notes for use

Back-up protection

The tables given provide the value (in kA, referring to the breaking capacity according to the IEC 60947-2 Standard) for which the back-up protection among the combination of selected circuit-breakers is verified. The tables cover the possible combinations between ABB SACE FORMULA series of moulded-case circuit-breakers and those between the above mentioned circuit-breakers and the ABB series of miniature circuit-breakers.

The values indicated in the tables refer to the voltage V_n of 400/415V AC for all the other coordinations.

Note

The following tables give the breaking capacities at 415V AC for circuit-breakers SACE FORMULA.

FORMULA @ 415V AC	
Versions	Icu [kA]
A	10
B	18
C	25
N	36
S	50

Caption

MCB = miniature circuit-breakers (S2, S800)

MCCB = moulded-case circuit-breakers (FORMULA)

For miniature circuit-breakers:

B = trip characteristic ($I_m=3...5I_n$)

C = trip characteristic ($I_m=5...10I_n$)

D = trip characteristic ($I_m=10...20I_n$)

K = trip characteristic ($I_m=8...14I_n$)

Z = trip characteristic ($I_m=2...3I_n$)

For solutions not shown in these tables, please contact ABB SACE Division.

Coordination tables (back-up)

MCCB - MCB (415V)

Back-up

Supply side circuit-breaker: MCCB

Load side circuit-breaker: MCB

MCCB-MCB @ 415 V

Load S.	Char.	In (A)	Supply S.	A1	A2	A1	A2	A1	A2
			Version	B		C		N	
			Icu (kA)	18		25		36	
S200	B,C,K,Z	0.5...10	10	16	16	25	25	30	36
		13...63							
S200M	B,C	0.5...10	15	16	16	25	25	30	36
		13...63							
S200P	B,C,D,K,Z	0.5...10	25					30	36
		13...25						30	36
		32...63		16	16	25	25	30	36
S280	B,C	80...100	6	16	16	16	16	16	36
S290	C,D	80...125	15	16	16	25	25	30	36
S800N	B,C,D	10...125	36						
S800S	B,C,D,K	10...125	50						

Coordination tables (back-up)

MCCB - MCCB (415V)

Back-up

Supply side circuit-breaker: MCCB

Load side circuit-breaker: MCCB

MCCB-MCCB @ 415 V

Load S.	Char.	Supply S.	A2	A2	A2	A3	A3
		Version	B	C	N	S	
		Icu (kA)	18	25	36	36	50
A1	A	10	18	25	36	25	25
A1	B	18		25	36	25	36
A2		18				25	36
A1	C	25			36	36	50
A2		25				36	50
A1	N	36					50
A2		36					50



Content

Information for reading and graphic symbols	5/2
Wiring diagrams of the circuit-breakers	5/3
Electrical accessories	5/4

Information for reading and graphic symbols

State of operation represented

The diagram is shown under the following conditions:

- circuit-breaker open;
- circuits without voltage;
- trip units not tripped.

Incompatibility

A1 A2

Accessory circuits cannot be supplied with single-pole circuit-breakers.

The applications indicated in figures 1-2-6, which are supplied as an alternative, can be supplied with two-pole circuit-breakers.

All the applications indicated in the figures can be supplied with three-pole and four-pole circuit-breakers. Figures 1-2-3-4 are provided as an alternative. Figures 5-6 are provided as an alternative.

A3

The circuits indicated in the following figures cannot be supplied at the same time on the same circuit-breaker:

- 1-2-3-4
- 5-6

Graphic Symbols (IEC 60617 and CEI 3-14...3-26 Standards)

	Thermal effect	•	Terminal		Change-over break before make contact
	Electromagnetic effect		Plug and socket (male and female)		Circuit-breaker with automatic release
----	Mechanical connection (link)		Resistor (general symbol)		Operating device (general symbol)
E---	Operated by pushing		Current transformer		Instantaneous overcurrent or rate-of-rise relay
F---	Operated by turning		Make contact		Overcurrent relay with inverse long time-lag characteristic
•	Connection of conductors		Break contact		

Wiring diagrams of the circuit-breakers

Operating status A1 A2

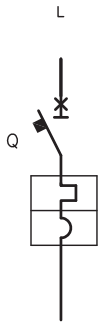

Single-pole circuit-breaker with thermomagnetic trip unit

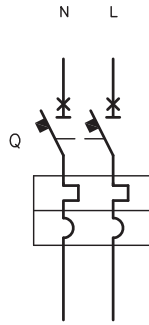

Two-pole circuit-breaker with thermomagnetic trip unit

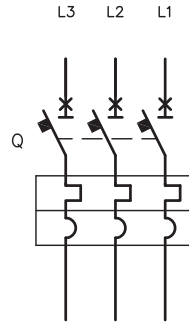

Three-pole circuit-breaker with thermomagnetic trip unit

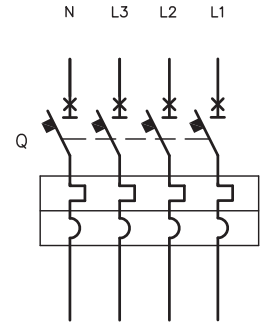

Four-pole circuit-breaker with thermomagnetic trip unit

Operating status A3

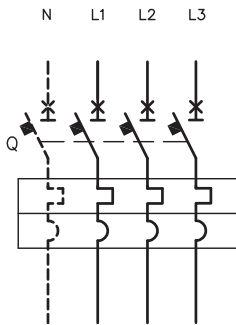

Three-pole/four-pole circuit-breaker with thermomagnetic trip unit

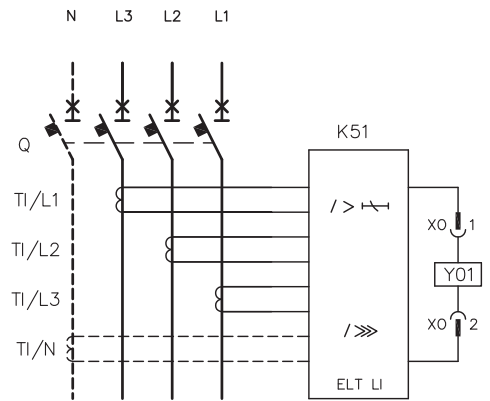

Three-pole/four-pole circuit-breaker with electronic trip unit

Caption

- Q = Main circuit-breaker
- K51 = Electronic trip unit ELT LI, with the following protection functions:
 - L overload protection with inverse long time-delay trip
 - I short-circuit protection with instantaneous time-delay trip
- TI/L1 = Current transformer placed on phase L1
- TI/L2 = Current transformer placed on phase L2
- TI/L3 = Current transformer placed on phase L3
- TI/N = Current transformer placed on the neutral
- X0 = Connector for the YO1 trip coil
- YO1 = Trip coil of the electronic trip unit

Electrical accessories

Shunt opening and undervoltage releases A1 A2

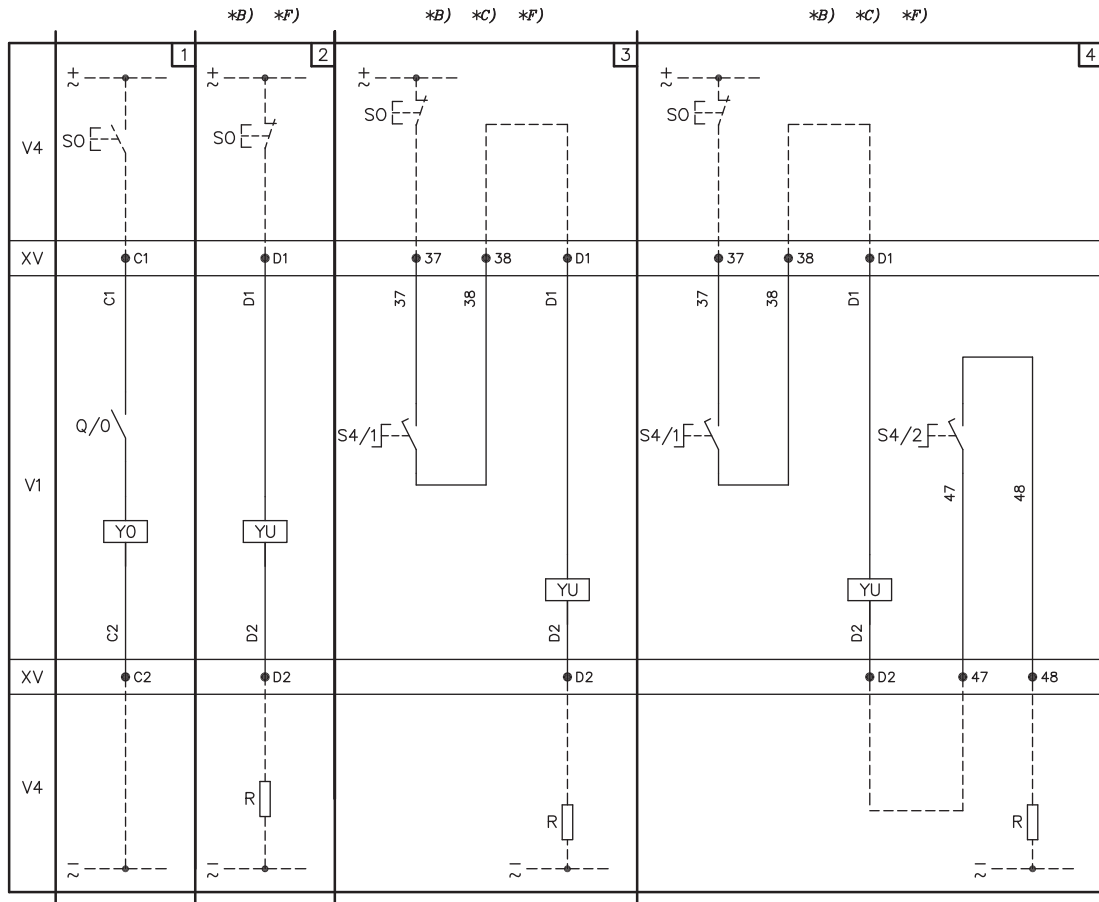

Figure:

- 1) Shunt opening release (SOR-C o YO)
- 2) Undervoltage release (UVR-C o YU)
- 3) Instantaneous undervoltage release with an early contact in series (AUE-C+UVR-C)
- 4) Instantaneous undervoltage release with two early contacts in series (AUE-C+UVR-C)

Notes

- B) The undervoltage release is supplied for power supply branched on the supply side of the circuit-breaker or from an independent source: circuit-breaker closing is only allowed with the release energised (the lock on closing is made mechanically).
- C) The S4/1 and S4/2 contacts shown in figures 3-4 open the circuit with circuit-breaker open and close it when a manual closing command is given by means of the rotary handle in accordance with the Standards regarding machine tools (closing does not take place in any case if the undervoltage release is not supplied).
- F) Additional external undervoltage resistor supplied at 250V DC or 380/440V AC.

Caption

- Q/0 = Circuit-breaker auxiliary contacts
R = Resistor (see note F)
S4/1-2 = Early auxiliary contacts activated by the rotary handle of the circuit-breaker (see note C)
SO = Pushbutton or contact for opening the circuit-breaker
V1 = Circuit-breaker applications
V4 = Indicative apparatus and connections for control and signalling, outside the circuit-breaker
XV = Terminal boards of the applications
YO = Shunt opening release (SOR-C)
YU = Undervoltage release (UVR-C) (see notes B and C)

Shunt opening and undervoltage releases A3

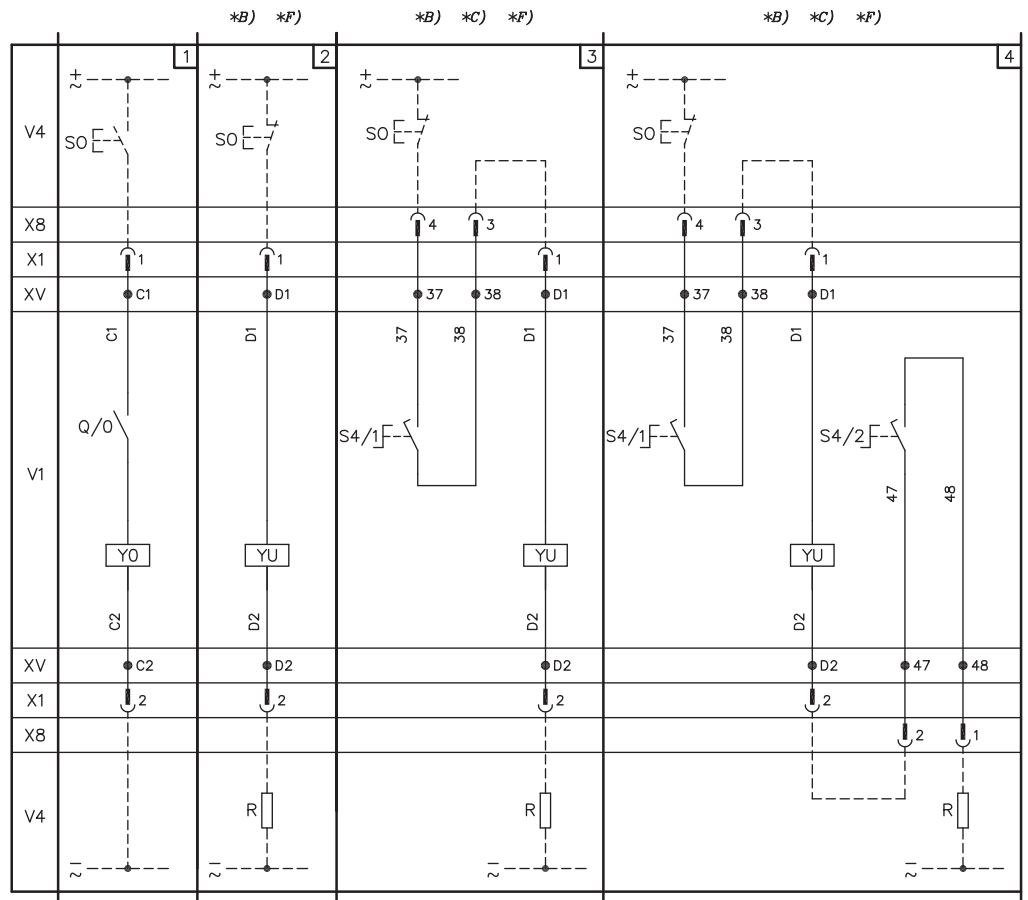

Figure:

- 1) Shunt opening release (SOR-C o YO)
- 2) Undervoltage release (UVR-C o YU)
- 3) Instantaneous undervoltage release with an early contact in series (AUE-C+UVR-C)
- 4) Instantaneous undervoltage release with two early contacts in series (AUE-C+UVR-C)

Notes

- B) The undervoltage release is supplied for power supply branched on the supply side of the circuit-breaker or from an independent source: circuit-breaker closing is only allowed with the release energised (the lock on closing is made mechanically).
- C) The S4/1 and S4/2 contacts shown in figures 3-4 open the circuit with circuit-breaker open and close it when a manual closing command is given by means of the rotary handle in accordance with the Standards regarding machine tools (closing does not take place in any case if the undervoltage release is not supplied).
- F) Additional external undervoltage resistor supplied at 250V DC or 380/440V AC.

Caption

- Q/0 = Circuit-breaker auxiliary contacts
R = Resistor (see note F)
S4/1-2 = Early auxiliary contacts activated by the rotary handle of the circuit-breaker (see note C)
SO = Pushbutton or contact for opening the circuit-breaker
V1 = Circuit-breaker applications
V4 = Indicative apparatus and connections for control and signalling, outside the circuit-breaker
XV = Terminal boards of the applications
YO = Shunt opening release (SOR-C)
YU = Undervoltage release (UVR-C) (see notes B and C)
X1, X8 = Connectors for the circuit-breaker auxiliary circuits

Electrical accessories

Auxiliary contacts A1 A2

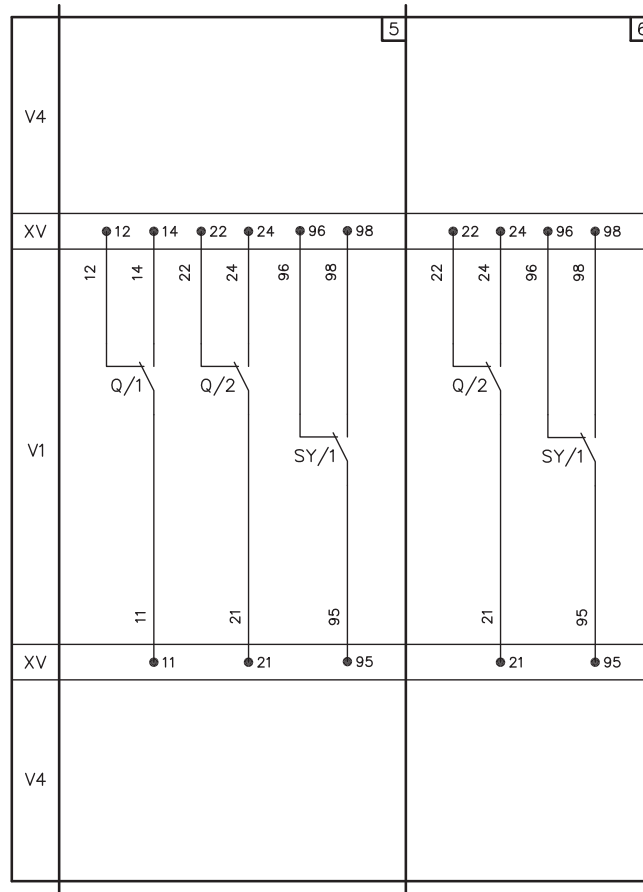

Figure:

- 5) Two changeover contacts for electrical signalling of circuit-breaker open/closed and one changeover contact for signalling circuit-breaker in tripped position due to thermomagnetic trip unit or SOR-C or UVR-C intervention (2Q+1SY)
- 6) One changeover contact for electrical signalling of circuit-breaker open/closed and one changeover contact for signalling circuit-breaker in tripped position due to thermomagnetic trip unit or SOR-C or UVR-C intervention (1Q+1SY)

Caption

- Q/1, 2 = Circuit-breaker auxiliary contacts
- SY = Contact for electrical signalling circuit-breaker open due to trip of the thermomagnetic trip unit YO (SOR-C), YU (UVR-C) (tripped position)
- V1 = Circuit-breaker applications
- V4 = Indicative apparatus and connections for control and signalling, outside the circuit-breaker
- XV = Terminal boards of the applications

Auxiliary contacts A3

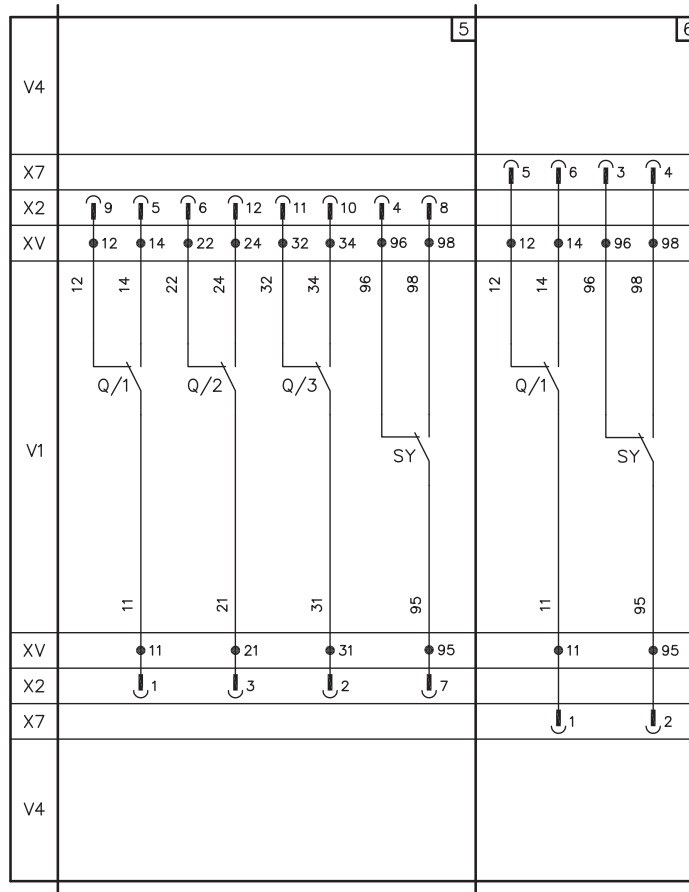

Figure:

- 5) Three changeover contacts for electrical signalling of circuit-breaker open/closed and one changeover contact for signalling circuit-breaker in tripped position due to thermomagnetic trip unit or SOR-C or UVR-C intervention (3Q+1SY)
- 6) One changeover contact for electrical signalling of circuit-breaker open/closed and one changeover contact for signalling circuit-breaker in tripped position due to thermomagnetic trip unit or SOR-C or UVR-C intervention (1Q+1SY)

Caption

- Q/1, 2, 3 = Circuit-breaker auxiliary contacts
- SY = Contact for electrical signalling circuit-breaker open due to trip of the thermomagnetic trip unit YO (SOR-C), YU (UVR-C) (tripped position)
- V1 = Circuit-breaker applications
- V4 = Indicative apparatus and connections for control and signalling, outside the circuit-breaker
- XV = Terminal boards of the applications
- X2, X7 = Connectors for the circuit-breaker auxiliary circuits



Overall dimensions

Content

FORMULA A1

Circuit-breaker and terminals	6/2
Accessories	6/8

FORMULA A2

Circuit-breaker and terminals	6/9
Accessories	6/15

FORMULA A3

Circuit-breaker and terminals	6/16
Accessories	6/20

FORMULA Link

FORMULA Link 250A	6/22
FORMULA Link 400A	6/23
FORMULA Link 630A	6/24
FORMULA Link 800A	6/25

Distances to be respected	6/26
---------------------------------	------

Overall dimensions

A1 - Circuit-breaker and terminals

Fixing onto the back plate

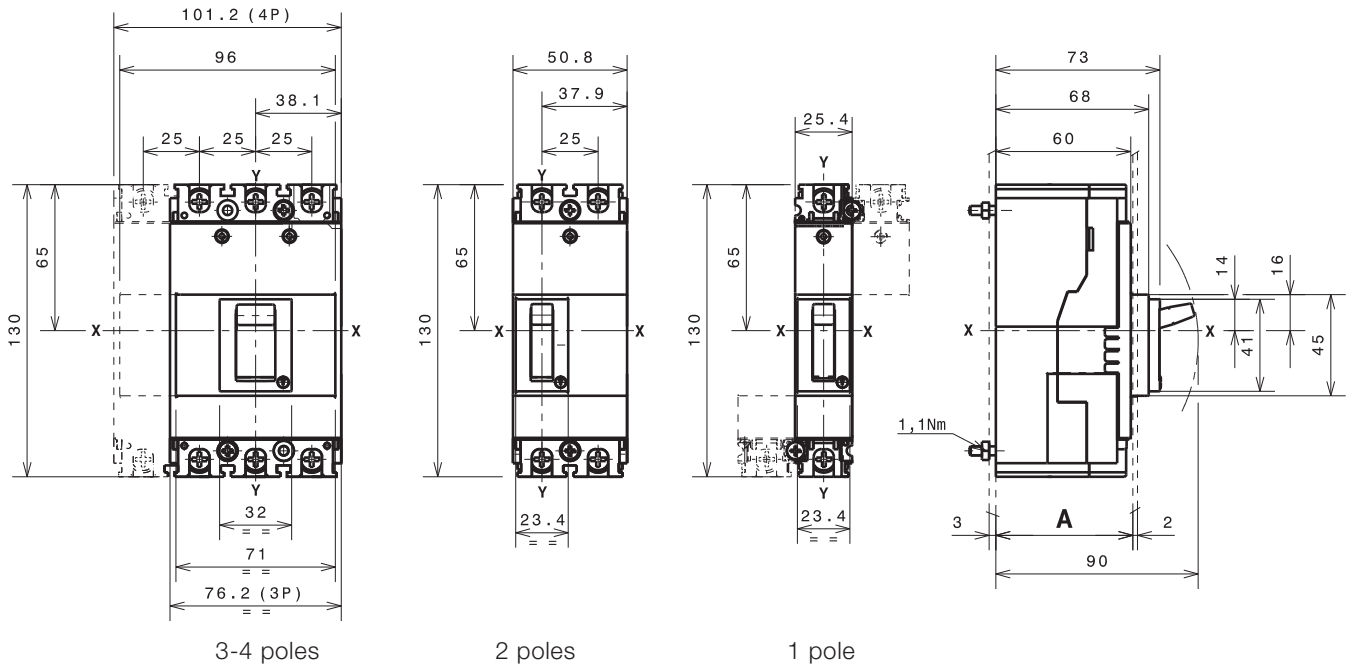

Distance between compartment door and back of switchboard		A [mm]
Without flange	I-II-III-IV poles	69
	I-II-III-IV poles	61

The circuit-breaker installed at:

- A=69 mm has the face around the operating lever extending from the compartment door;
- A=61 mm has the face around the operating lever and steel with construction characteristics extending from the compartment door.

Fixing onto DIN 50022 rail

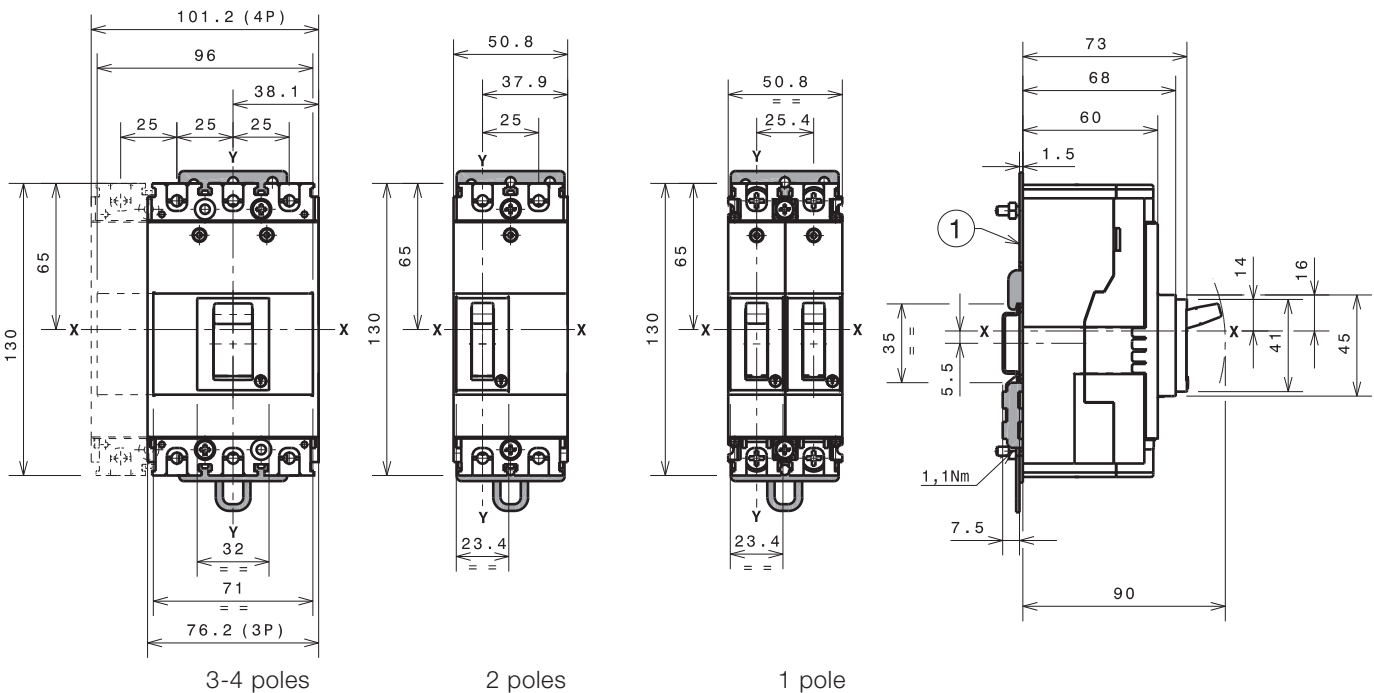

Caption

- ① Fixing bracket

Drilling templates for support sheet

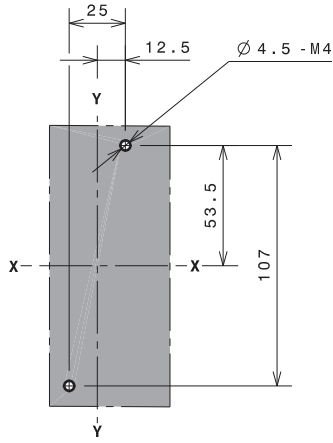

1-3-4 poles

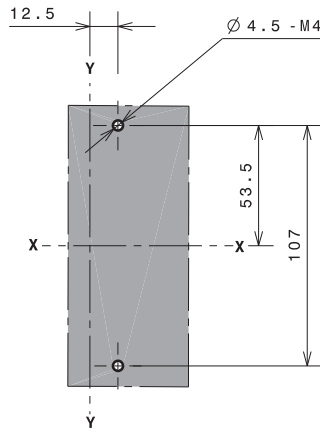

2 poles

Drilling templates for compartment door

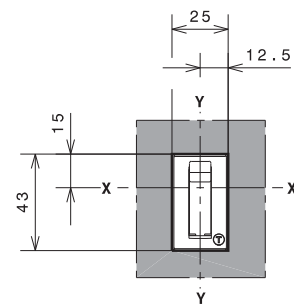
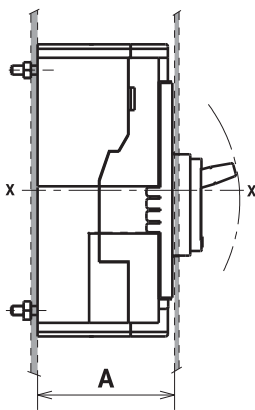

A = 69mm
1-2 poles

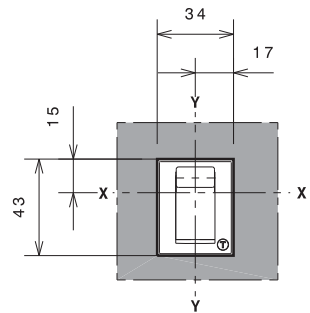

A = 69mm
3-4 poles

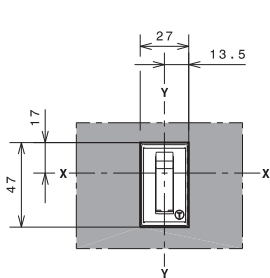

A = 61mm
1 pole

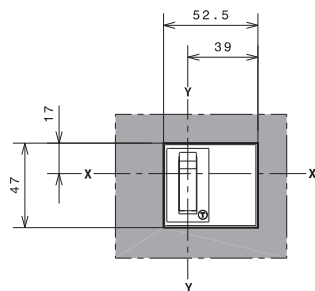

A = 61mm
2 poles

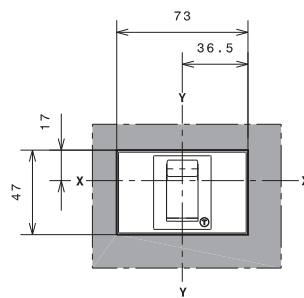

A = 61mm
3 poles

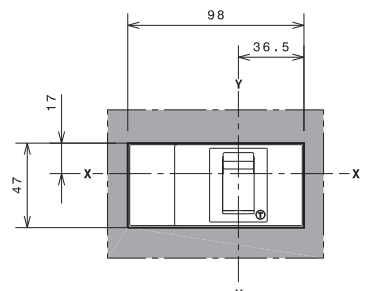

A = 61mm
4 poles

ES Terminals

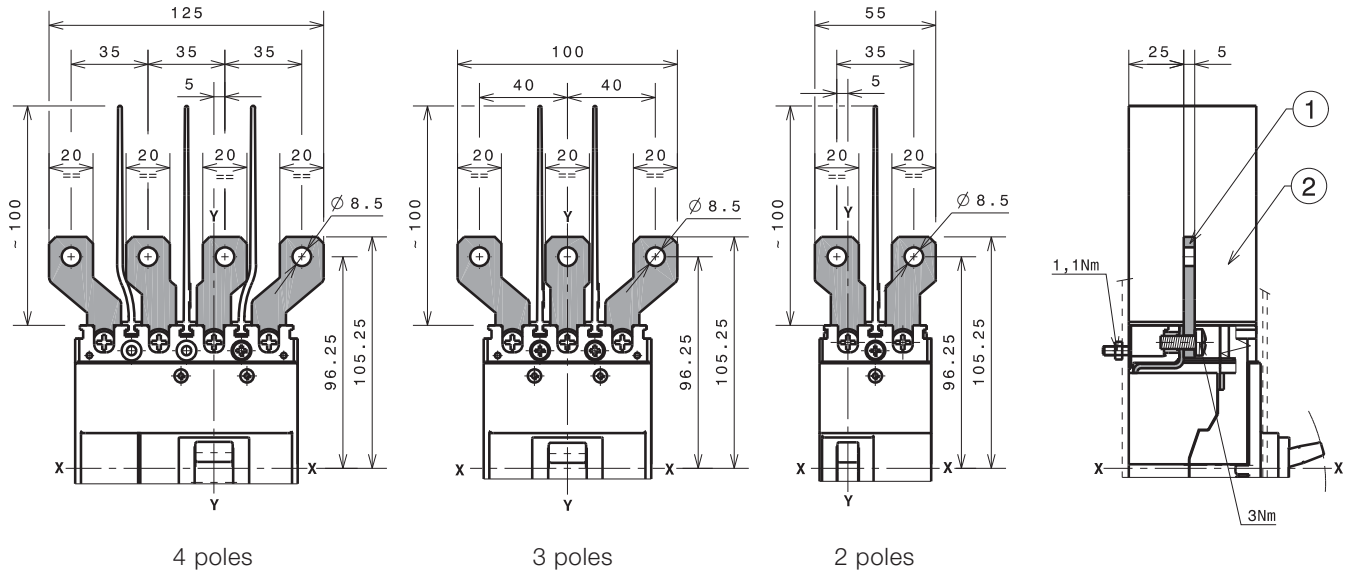

Caption

- ① Front extended spread terminals
- ② 100mm insulating barriers between the terminals (compulsory) supplied

Overall dimensions

A1 - Circuit-breaker and terminals

FCCuAl 1x25...50mm² Terminals

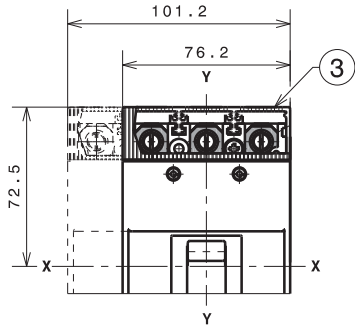

3-4 poles

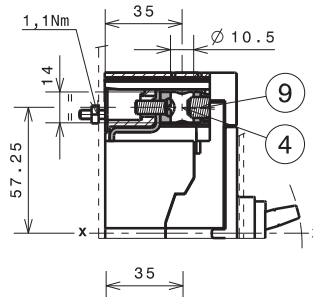

3-4 poles

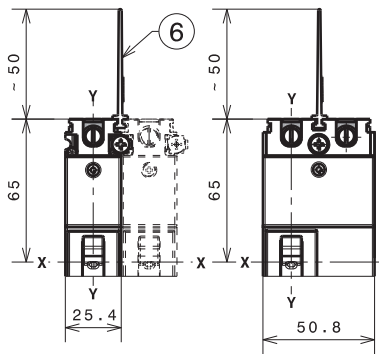

1-2 poles

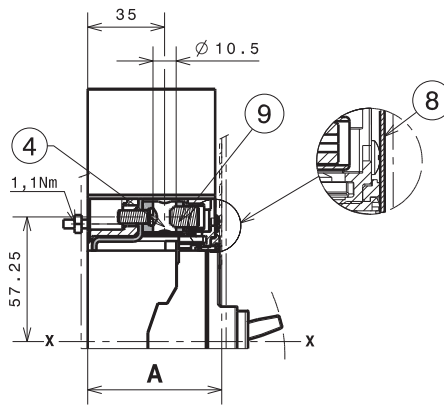

1-2 poles

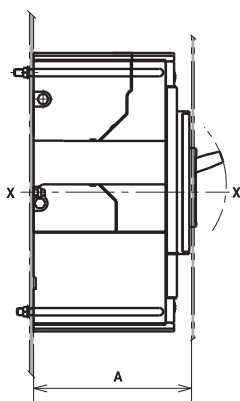

1-2 poles

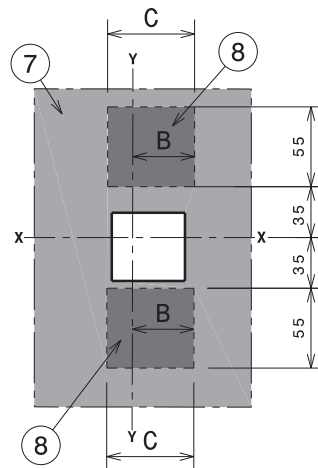

1-2 poles

Caption

- ③ Bottom terminal covers with IP40 degree of protection (compulsory)
- ④ FCCuAl 50mm² terminals
- ⑥ 50mm insulating barriers between the terminals (compulsory) not supplied with FCCuAl terminals kit, but with the circuit-breaker in base version
- ⑦ Compartment door drilling template and fixing insulation (provided by customer)
- ⑧ Compulsory internal 1 pole - 2 pole insulation plates (provided by customer)

	A [mm]	B [mm]	C [mm]	
Without flange	69	33	66	1 POLE
	69	58	91	2 POLES
	61*	33	66	1 POLE
	61*	58	91	2 POLES

* Distance only possible with insulation plate max 1 mm thick

FCCuAl 1x1...25mm² Terminals

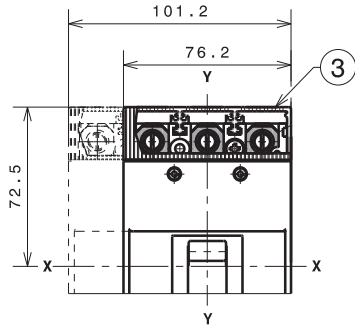

3-4 poles

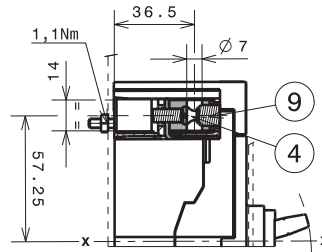

3-4 poles

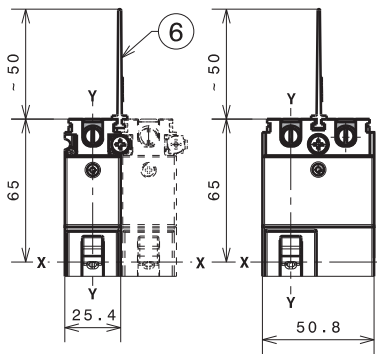

1-2 poles

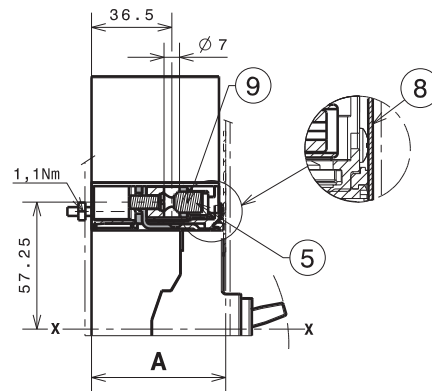

1-2 poles

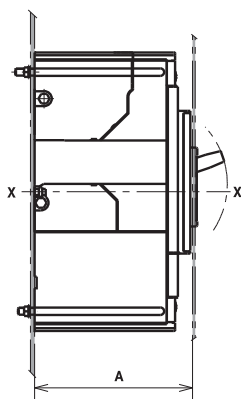

1-2 poles

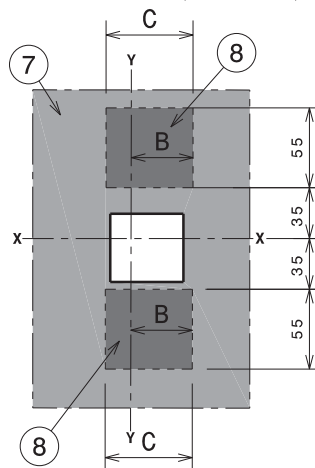

1-2 poles

Caption

- ③ Bottom terminal covers with IP40 degree of protection (compulsory)
- ⑤ FCCuAl 25mm² terminals
- ⑥ 50mm insulating barriers between the terminals (compulsory) not supplied with FCCuAl terminals kit, but with the circuit-breaker in base version
- ⑦ Compartment door drilling template and fixing insulation (provided by customer)
- ⑧ Compulsory internal 1 pole - 2 pole insulation plates (provided by customer)

	A [mm]	B [mm]	C [mm]	
Without flange	69	33	66	1 POLE
	69	58	91	2 POLES
	61*	33	66	1 POLE
	61*	58	91	2 POLES

* Distance only possible with insulation plate max 1 mm thick

Overall dimensions

A1 - Accessories

Rotary handle operating mechanism on circuit-breaker and compartment door drilling template (RHD)

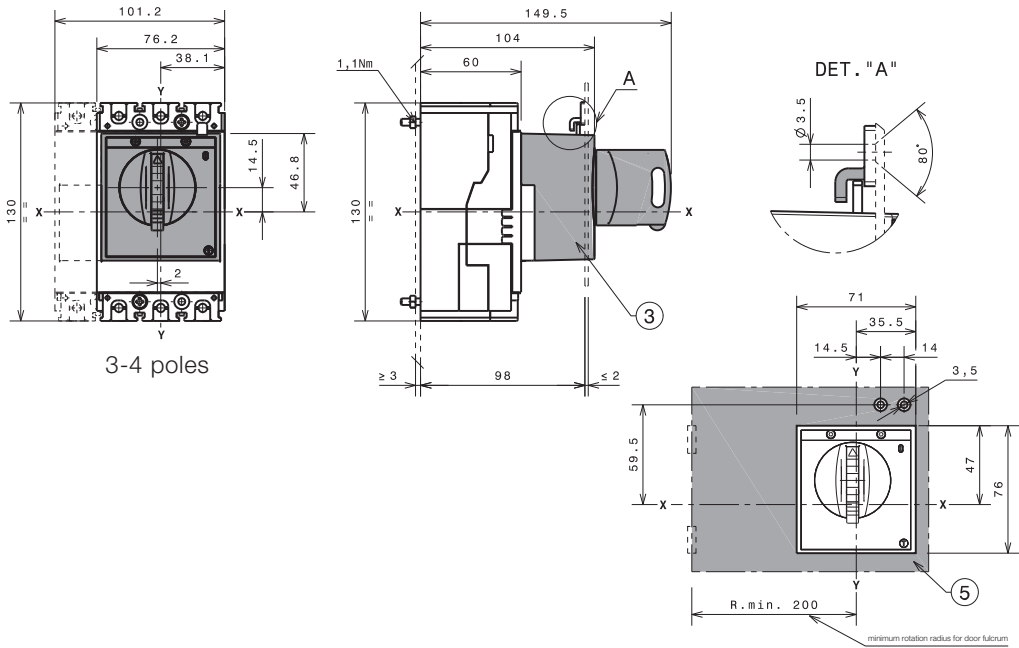

Caption

- ③ Rotary handle operating mechanism on circuit-breaker
- ⑤ Template for drilling compartment with direct handle

Rotary handle operating mechanism on compartment door and compartment door drilling template (RHE)

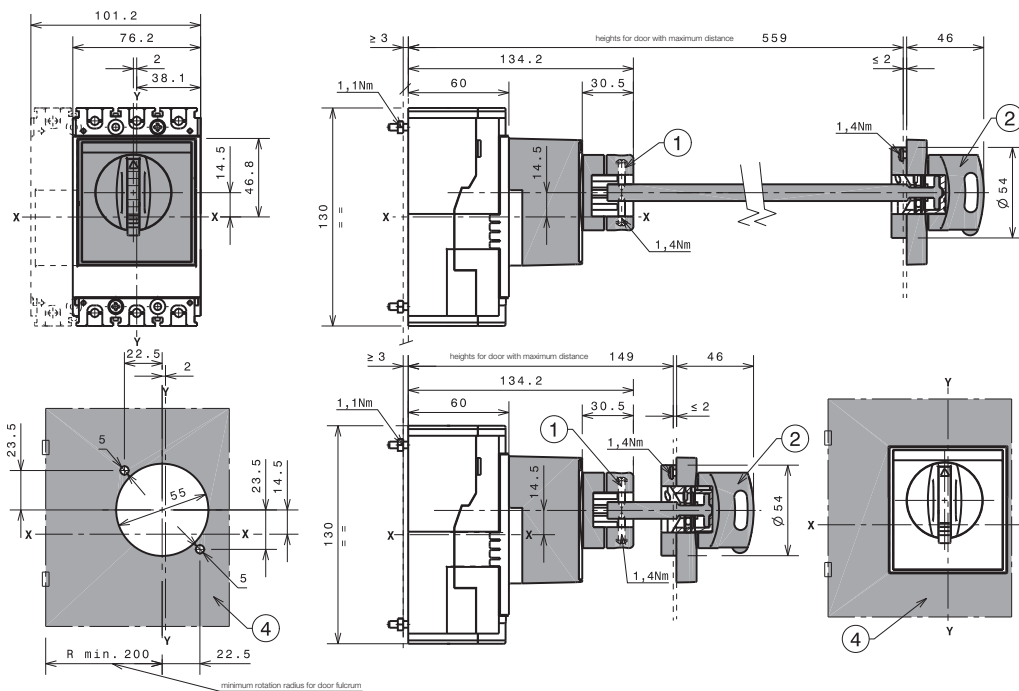

Caption

- ① Transmission group
- ② Transmitted rotary handle operating mechanism
- ④ Template for drilling compartment with transmitted rotary handle

Overall dimensions

A2 - Circuit-breaker and terminals

Fixing on the back plate

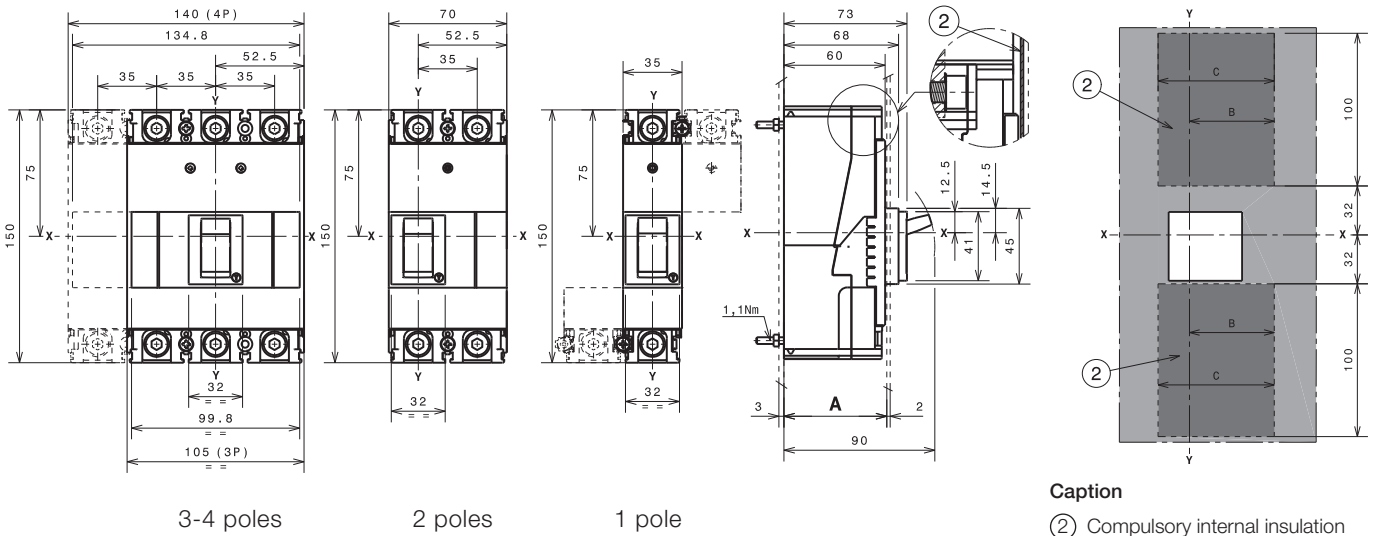

2 Compulsory internal insulation plates (provided by customer) for use $U_e \geq 415$ V

Distance between compartment door and back of switchboard		A [mm]
Without flange	I-II-III-IV poles	69
	I-II-III-IV poles	61

	A [mm]	B [mm]	C [mm]	
Without flange	61	42.5	85	1 POLE
	61	77.5	120	2 POLES
	61	77.5	155	3 POLES
	61	77.5	190	4 POLES
	69	42.5	85	1 POLE
	69	77.5	120	2 POLES
	69	77.5	155	3 POLES
	69	77.5	190	4 POLES

The circuit-breaker installed at:
 - A=69 mm has the face around the operating lever extending from the compartment door;
 - A=61 mm has the face around the operating lever and steel with construction characteristics extending from the compartment door.

Fixing onto DIN 50022 rail

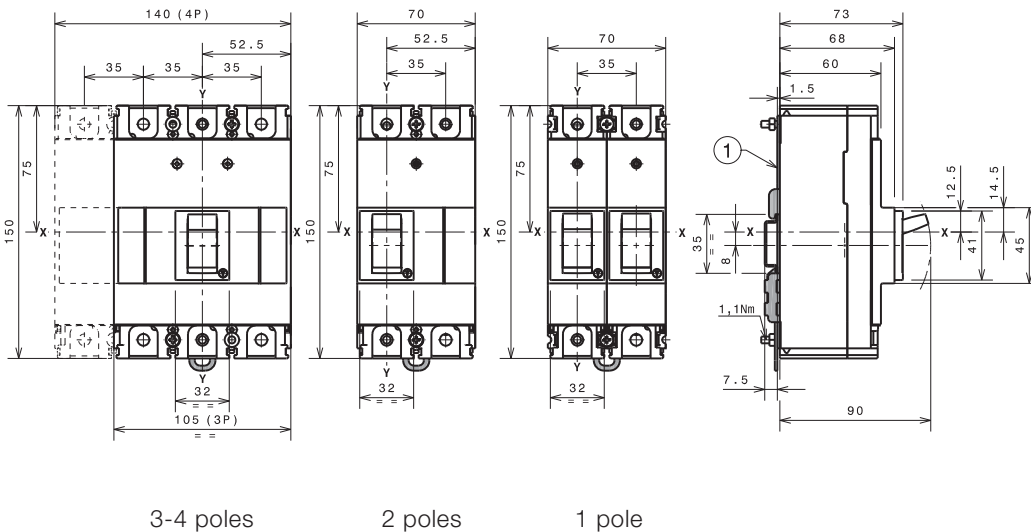

1 Fixing bracket

Overall dimensions

A2 - Circuit-breaker and terminals

Drilling templates for support sheet

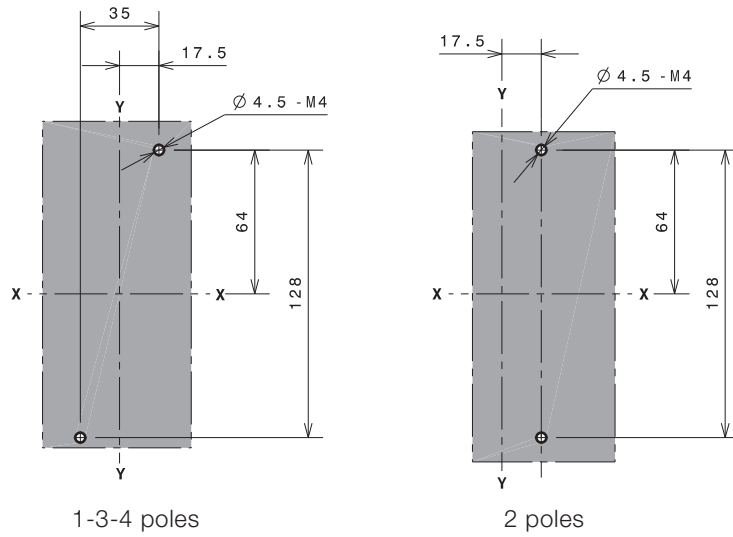

Compartment door drilling templates

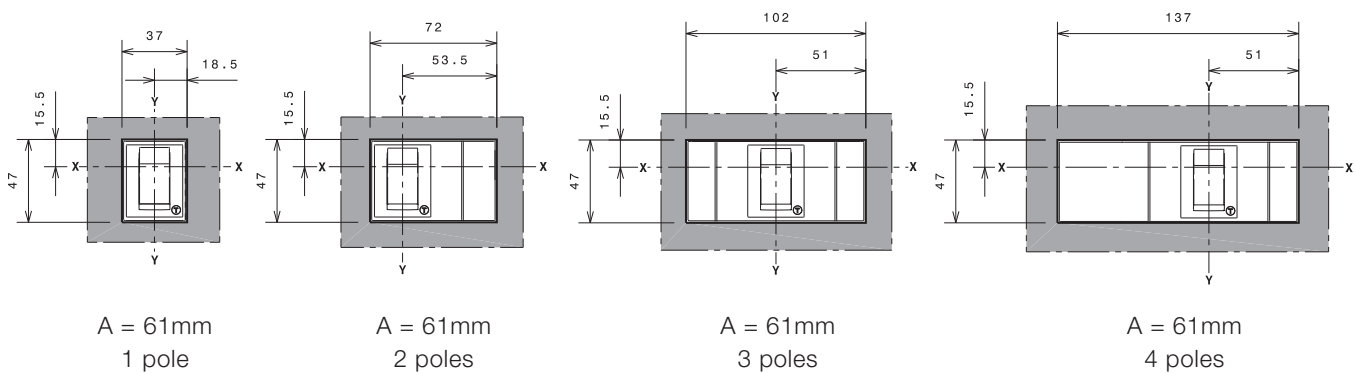
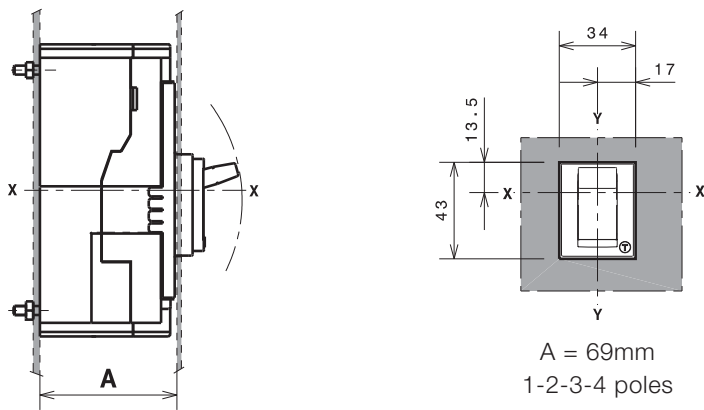

F Terminals

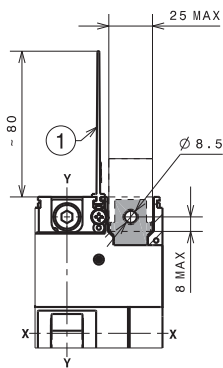

2-3-4 poles

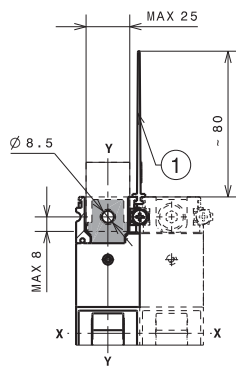

1 poles

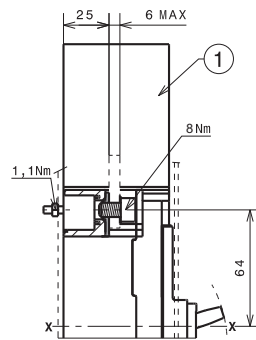

Caption

- ① 80mm insulating barriers between the terminals (compulsory) supplied

EF Terminals

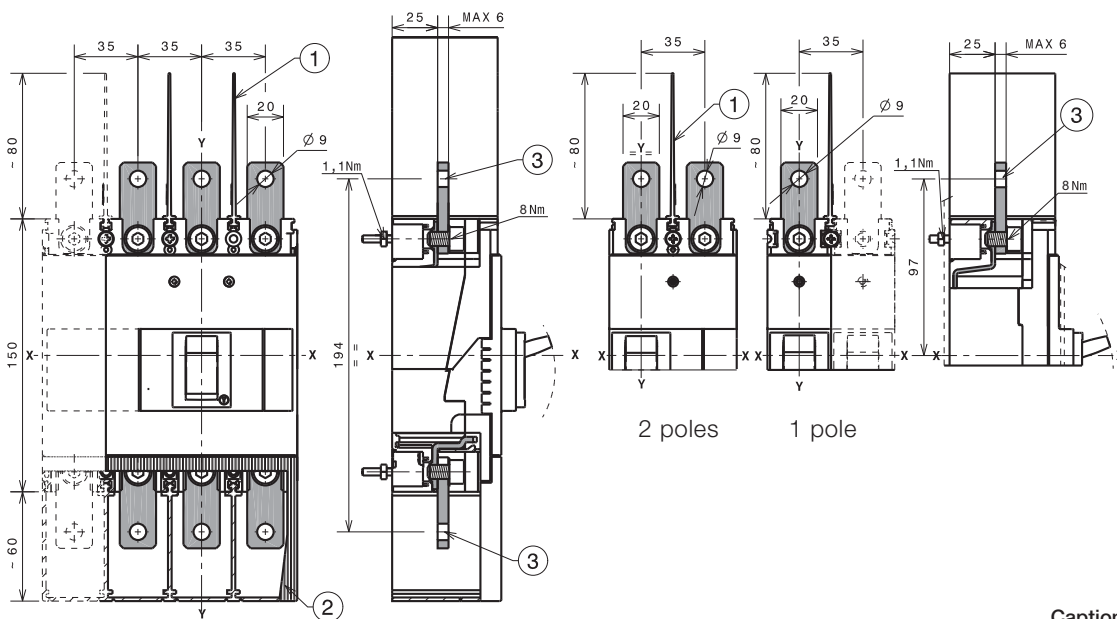

3-4 poles

2 poles

1 pole

Caption

- ① 80mm insulating barriers between the terminals (compulsory) not supplied with EF terminals kit, but with the circuit-breaker in base version
- ② Top terminal covers with IP40 degree of protection (on request)
- ③ Front extended terminals

Overall dimensions

A2 - Circuit-breaker and terminals

ES Terminals

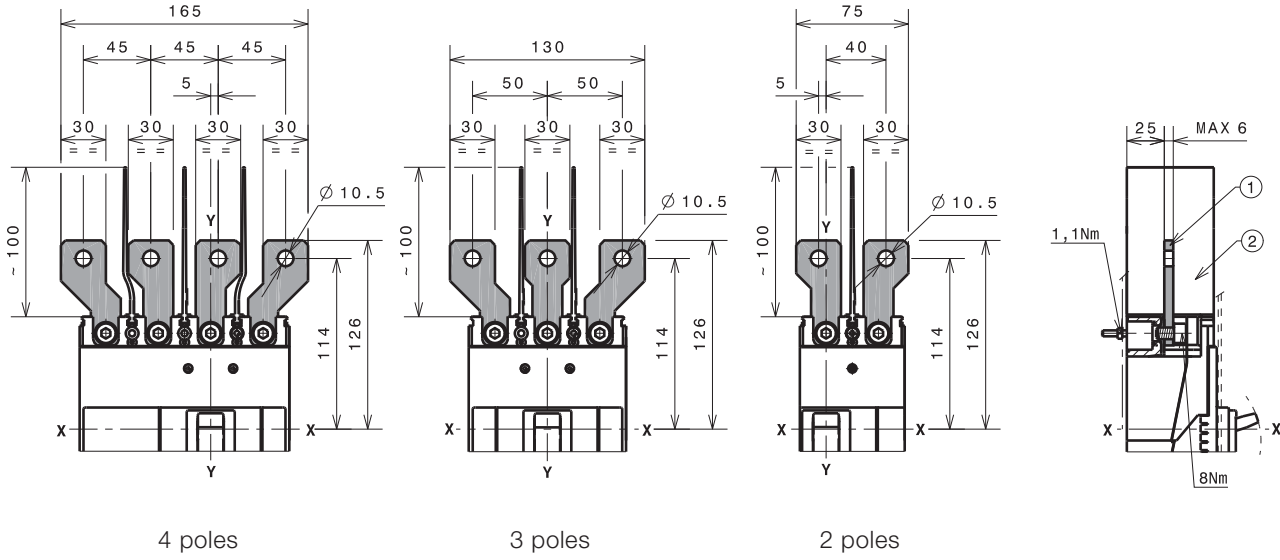

Caption

- ① Front extended spread terminals
- ② 100mm insulating barriers between the terminals (compulsory) supplied

FCCuAl 1x120...185mm² Terminals

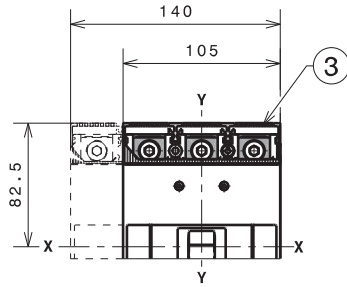

3-4 poles

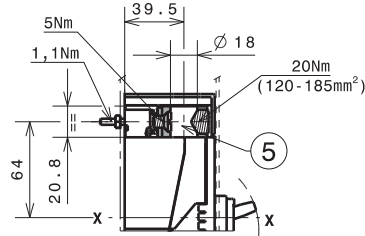

3-4 poles

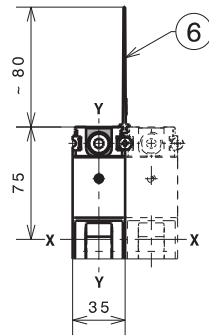

1 poles

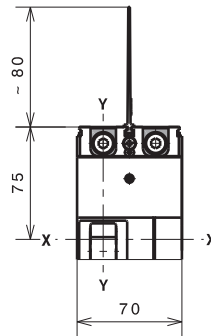

2 poles

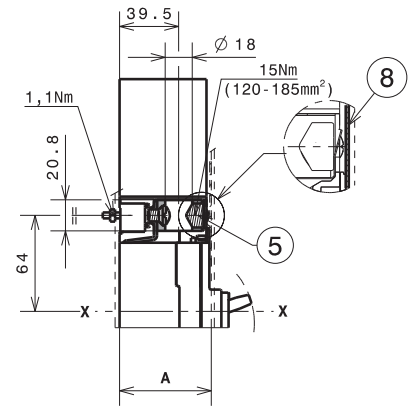

1-2 poles

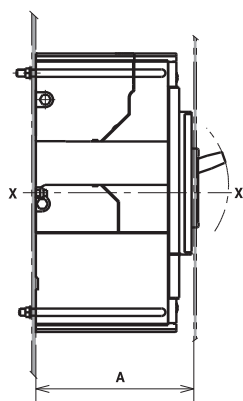

1-2 poles

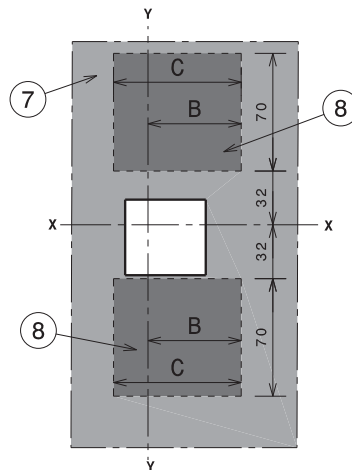

1-2 poles

If terminals are mounted on top of circuit-breaker, I_{cu}=50% and I_{cs}=I_{cu}.

Caption

- ③ Bottom terminal covers with IP40 degree of protection (compulsory)
- ⑤ Terminals FCCuAl 185mm²
- ⑥ 80mm insulating barriers between the terminals (compulsory) not supplied with FCCuAl terminals kit, but with the circuit-breaker in base version
- ⑦ Compartment door drilling template and fixing insulation (provided by customer) 1 pole - 2 poles
- ⑧ Compulsory internal insulation plates (provided by customer) max 1mm thick

	A [mm]	B [mm]	C [mm]	
Without flange	69	42.5	85	1 POLE
	69	77.5	120	2 POLES
	61	42.5	85	1 POLE
	61	77.5	120	2 POLES

Overall dimensions

A2 - Circuit-breaker and terminals

FCCuAl 1x50...150mm² Terminals

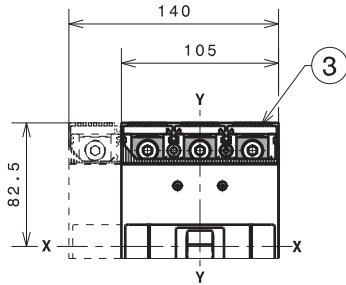

3-4 poles

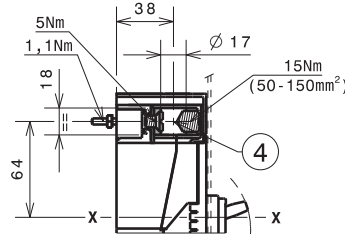

3-4 poles

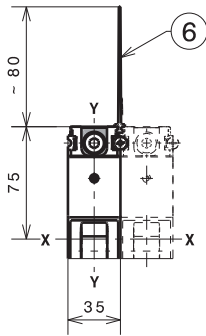

1 poles

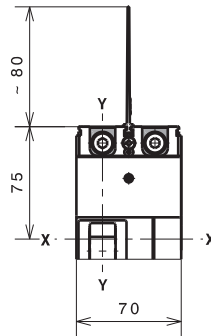

2 poles

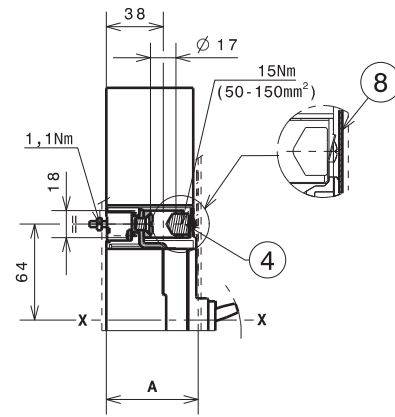

1-2 poles

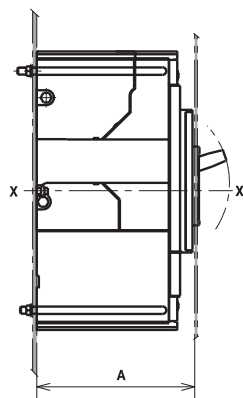

1-2 poles

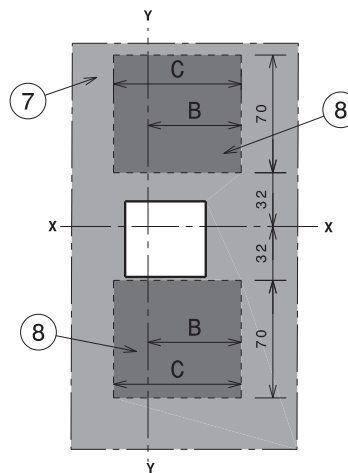

1-2 poles

If terminals are mounted on top of circuit-breaker, Icu=50% and Ics=Icu.

Caption

- ③ Bottom terminal covers with IP40 degree of protection (compulsory)
- ④ Terminals FCCuAl 150mm²
- ⑥ 80mm insulating barriers between the terminals (compulsory) not supplied with FCCuAl terminals kit, but with the circuit-breaker in base version
- ⑦ Compartment door drilling template and fixing insulation (provided by customer) 1 pole - 2 poles
- ⑧ Compulsory internal insulation plates (provided by customer) max 1mm thick

	A [mm]	B [mm]	C [mm]	
Without flange	69	42.5	85	1 POLE
	69	77.5	120	2 POLES
	61	42.5	85	1 POLE
	61	77.5	120	2 POLES

Overall dimensions

A2 - Accessories

Rotary handle operating mechanism on compartment door and compartment door drilling template (RHD)

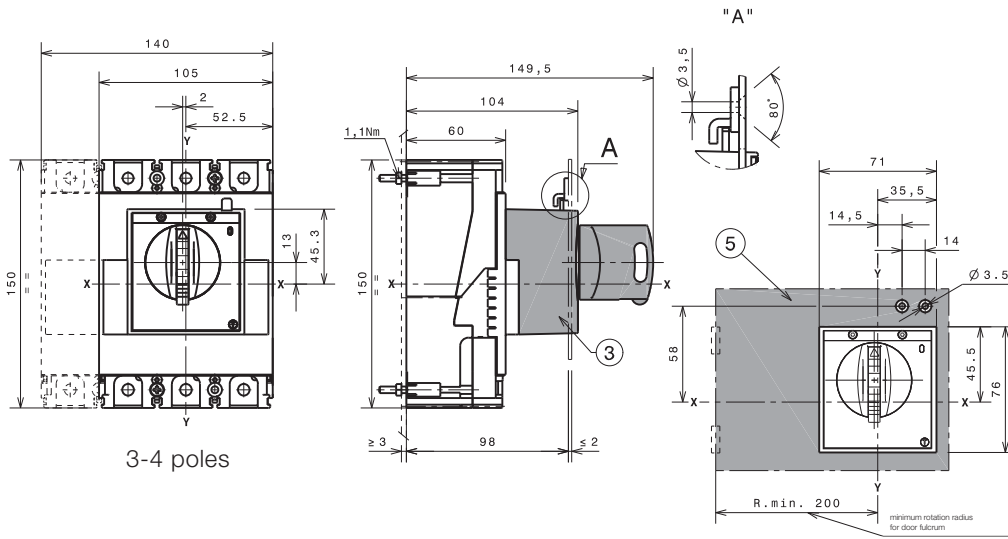

Caption

- ③ Rotary handle operating mechanism on circuit-breaker
- ⑤ Template for compartment drilling with direct handle

Rotary handle operating mechanism on circuit-breaker and compartment door drilling template (RHE)

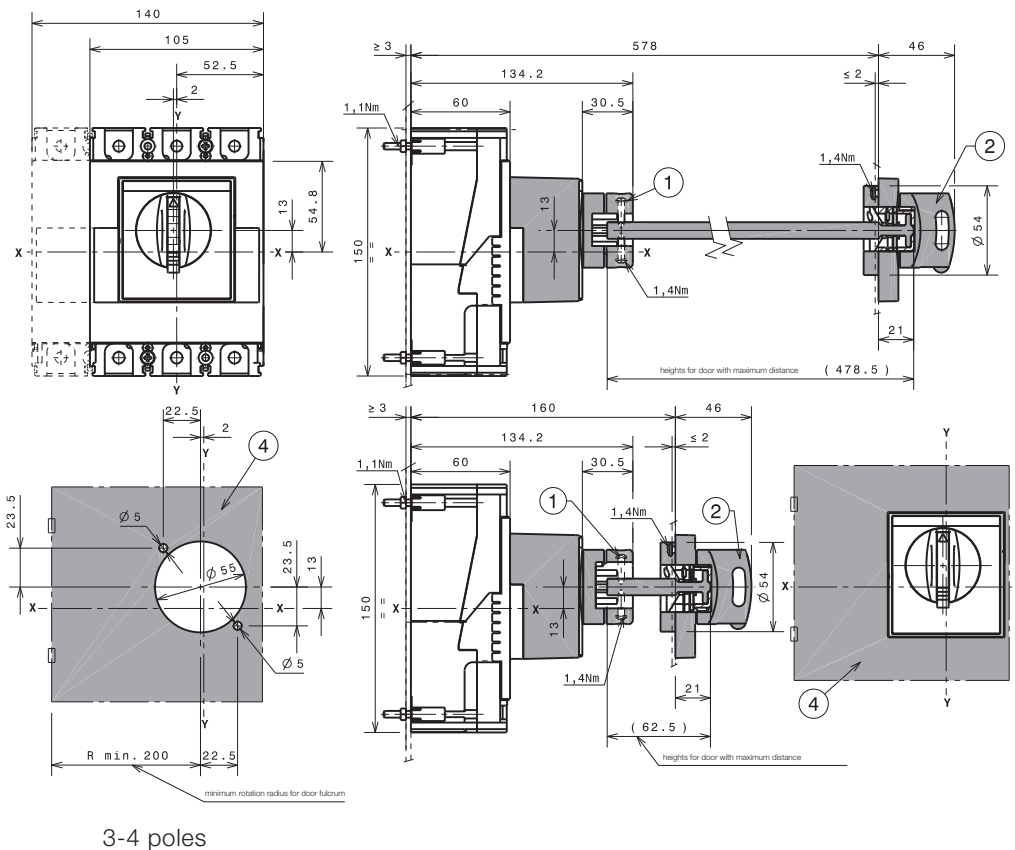

Caption

- ① Transmission group
- ② Transmitted rotary handle operating mechanism
- ④ Template for drilling compartment with transmitted rotary handle

Overall dimensions

A3 - Circuit-breaker and terminals

Fixing onto back plate

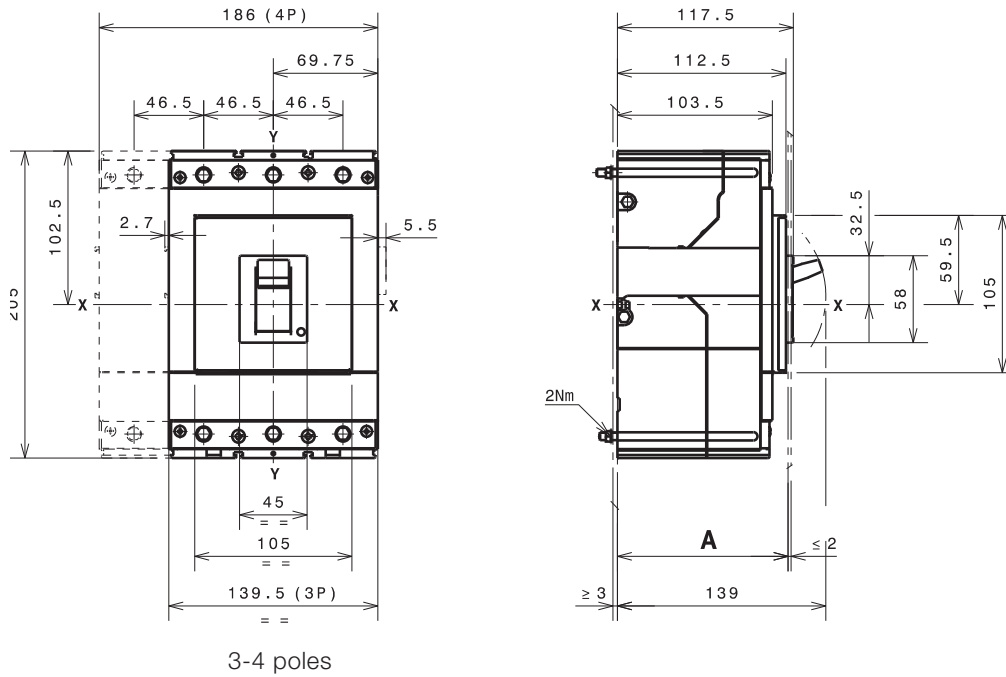

Distance between compartment door and back of switchboard		A [mm]
Without flange	I-II-III-IV poles	105
	I-II-III-IV poles	114

The circuit-breaker installed at:

- A=69 mm has the face around the operating lever extending from the compartment door;
- A=61 mm has the face around the operating lever and steel with construction characteristics extending from the compartment door.

Support sheet drilling templates

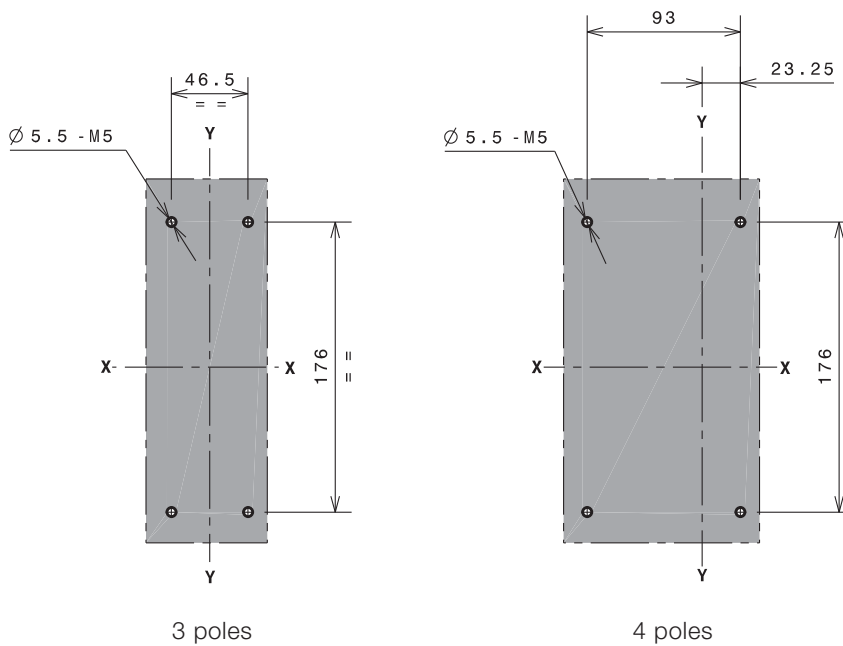

Compartment door drilling templates (without flange)

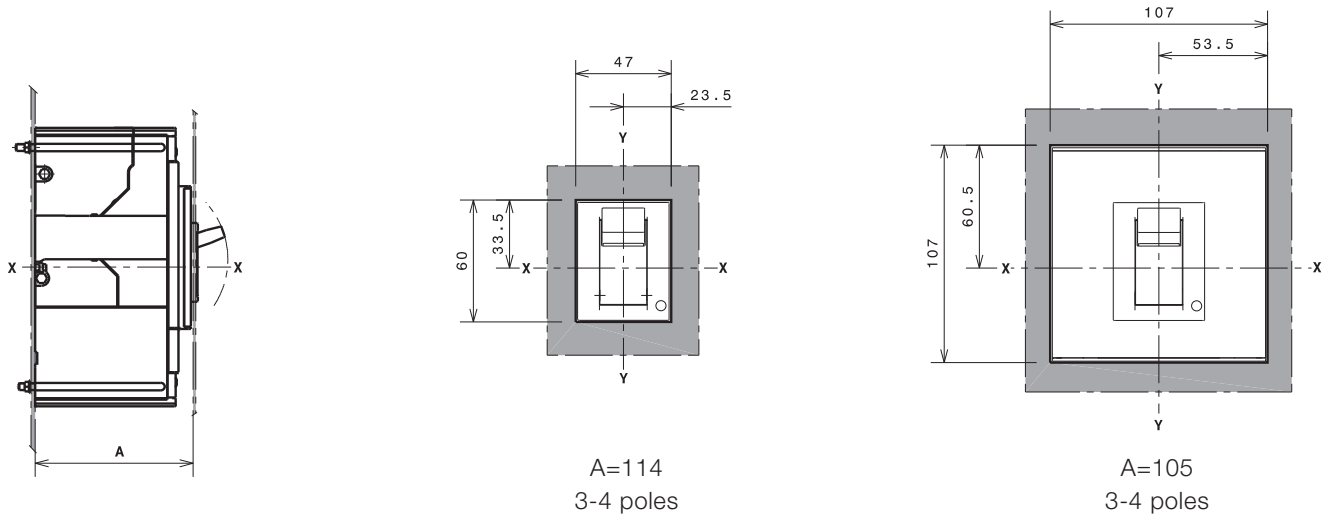

F Terminals

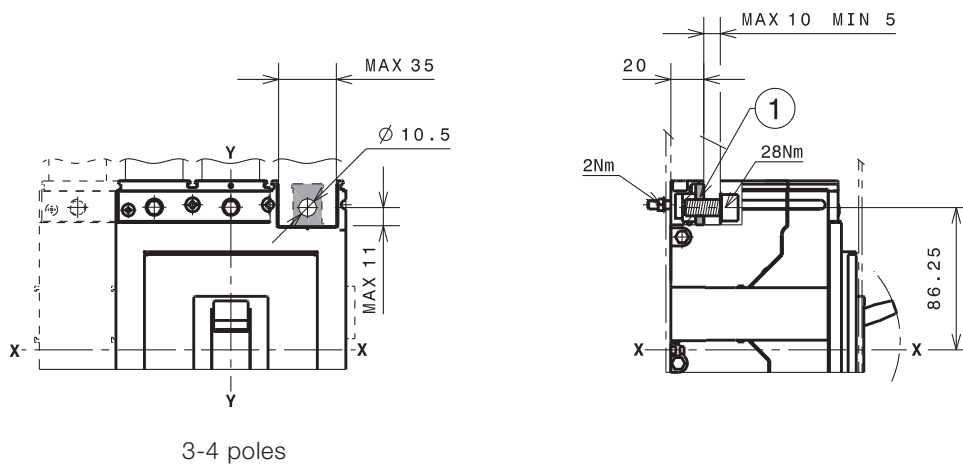

Caption

- ① Front terminals for busbar connection

Overall dimensions

A3 - Circuit-breaker and terminals

EF Terminals

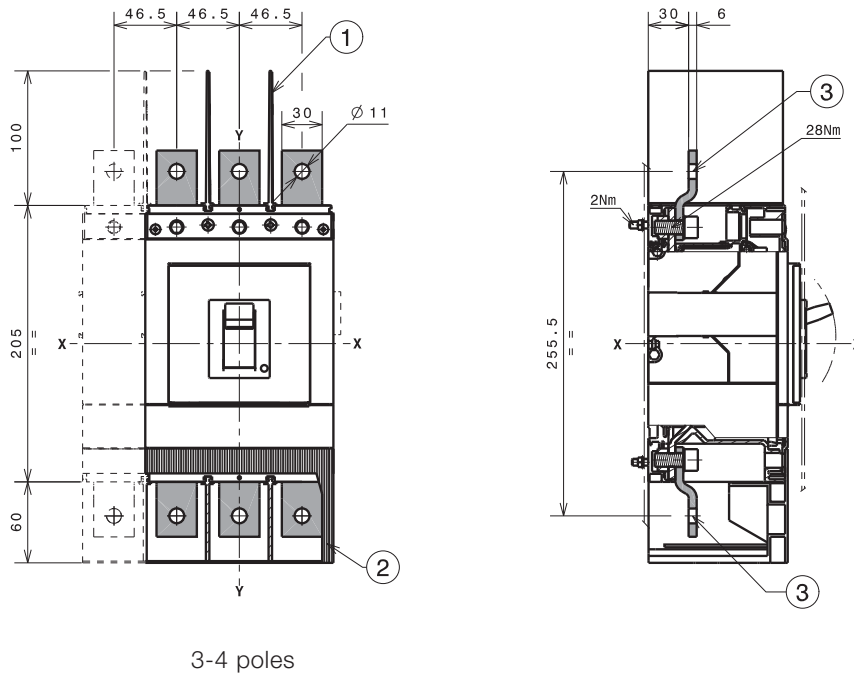

Caption

- ① 100mm insulating barriers between terminals (compulsory) supplied
- ② High terminal covers with degree of protection IP40 (on request)
- ③ Front extended terminals

ES Terminals

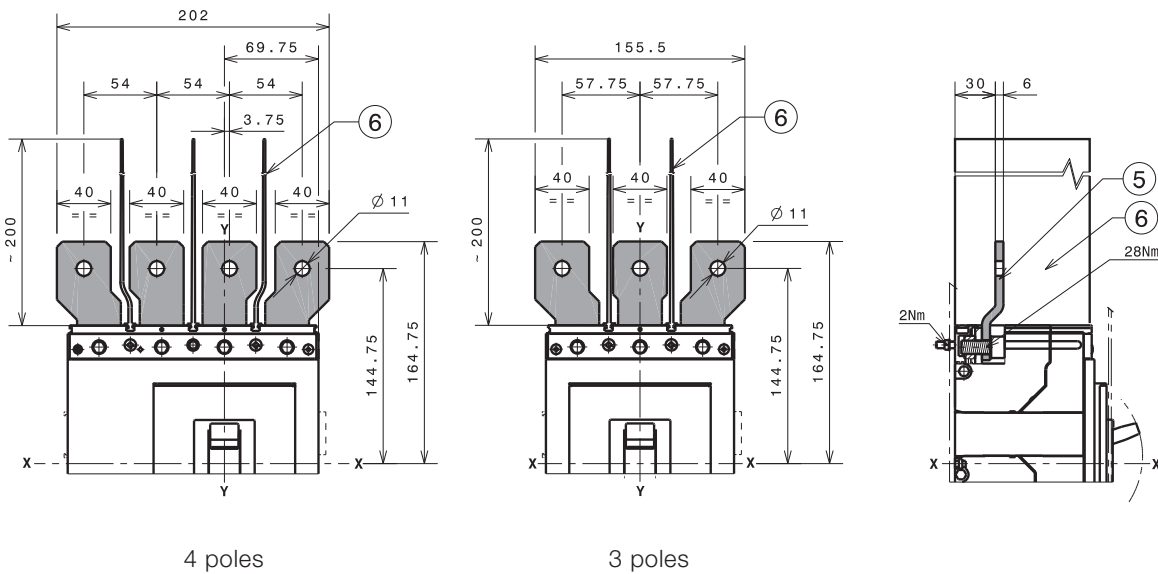

Caption

- ⑤ Front extended spread terminals
- ⑥ Insulating barriers between terminals (compulsory) supplied

FCCuAl 1x185...300mm² Terminals

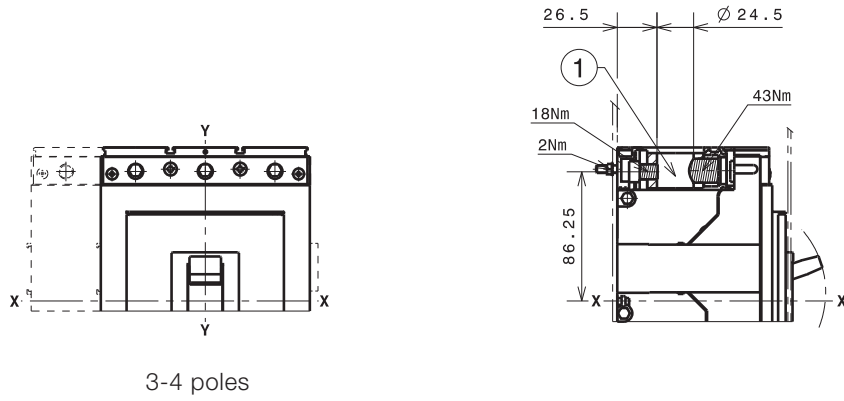

Caption

- ① Front terminals for busbar connection 300mm² CuAl

FCCuAl 2x95...240mm² Terminals

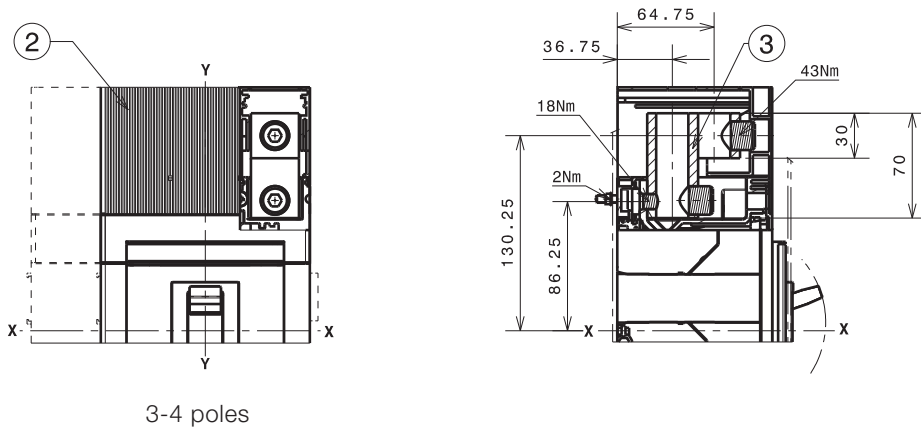

Caption

- ① 60mm high terminal covers (compulsory) supplied

Overall dimensions

A3 - Accessories

Rotary handle operating mechanism on circuit-breaker + Compartment door drilling template (RHD)

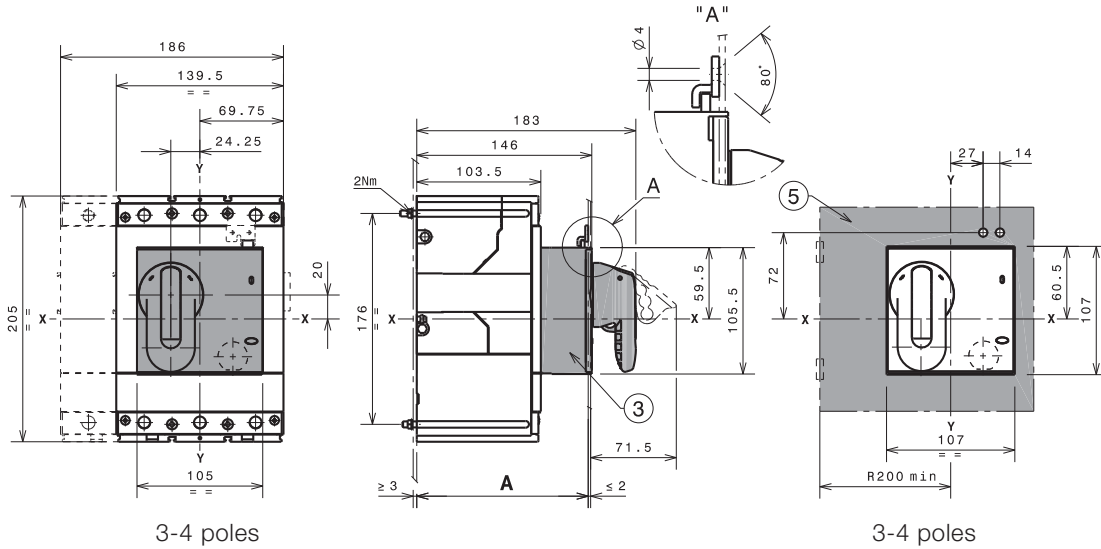

3-4 poles

3-4 poles

Caption

- ③ Rotary handle operating mechanism on circuit-breaker
- ⑤ Template for drilling compartment with direct handle

Rotary handle operating mechanism on compartment door + Compartment door drilling template (RHE)

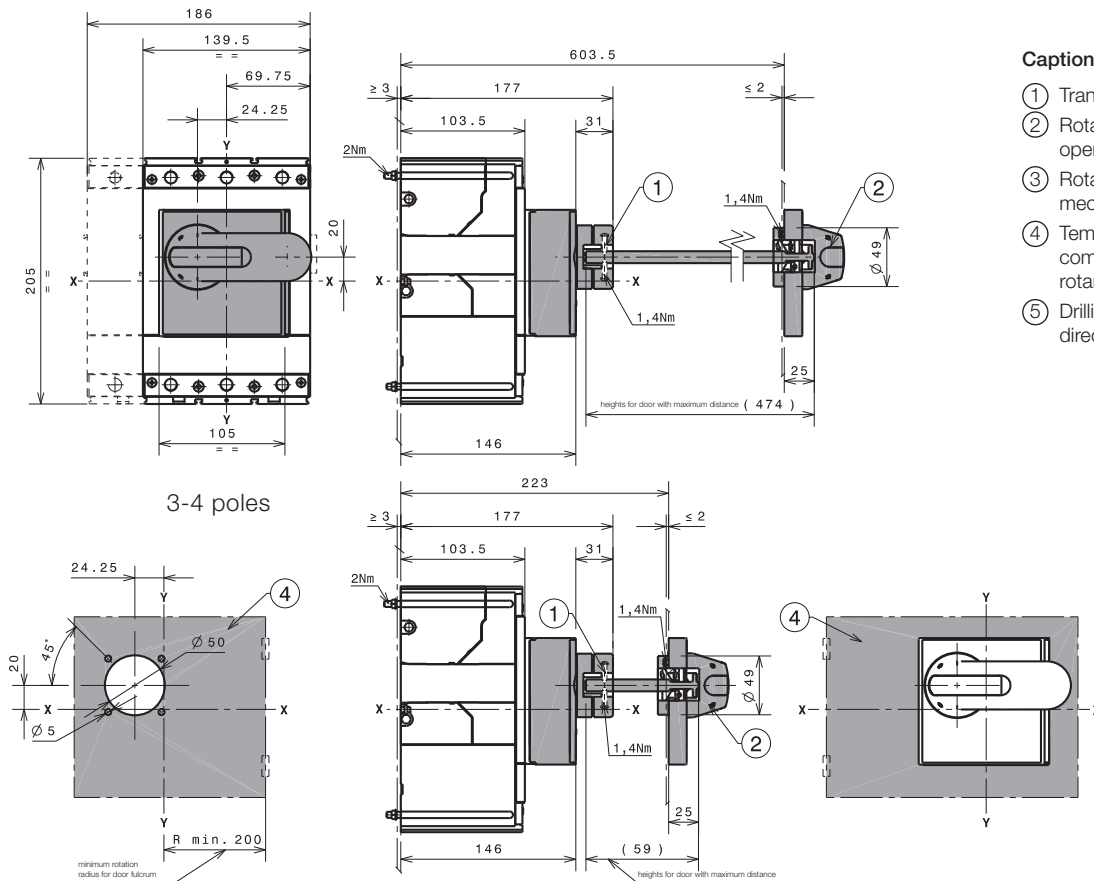

3-4 poles

Caption

- ① Transmission unit
- ② Rotary transmitted handle operating mechanism
- ③ Rotary handle operating mechanism on circuit-breaker
- ④ Template for drilling compartment with transmitted rotary handle
- ⑤ Drilling for door template with direct handle

Front for lock operating mechanism (FLD)

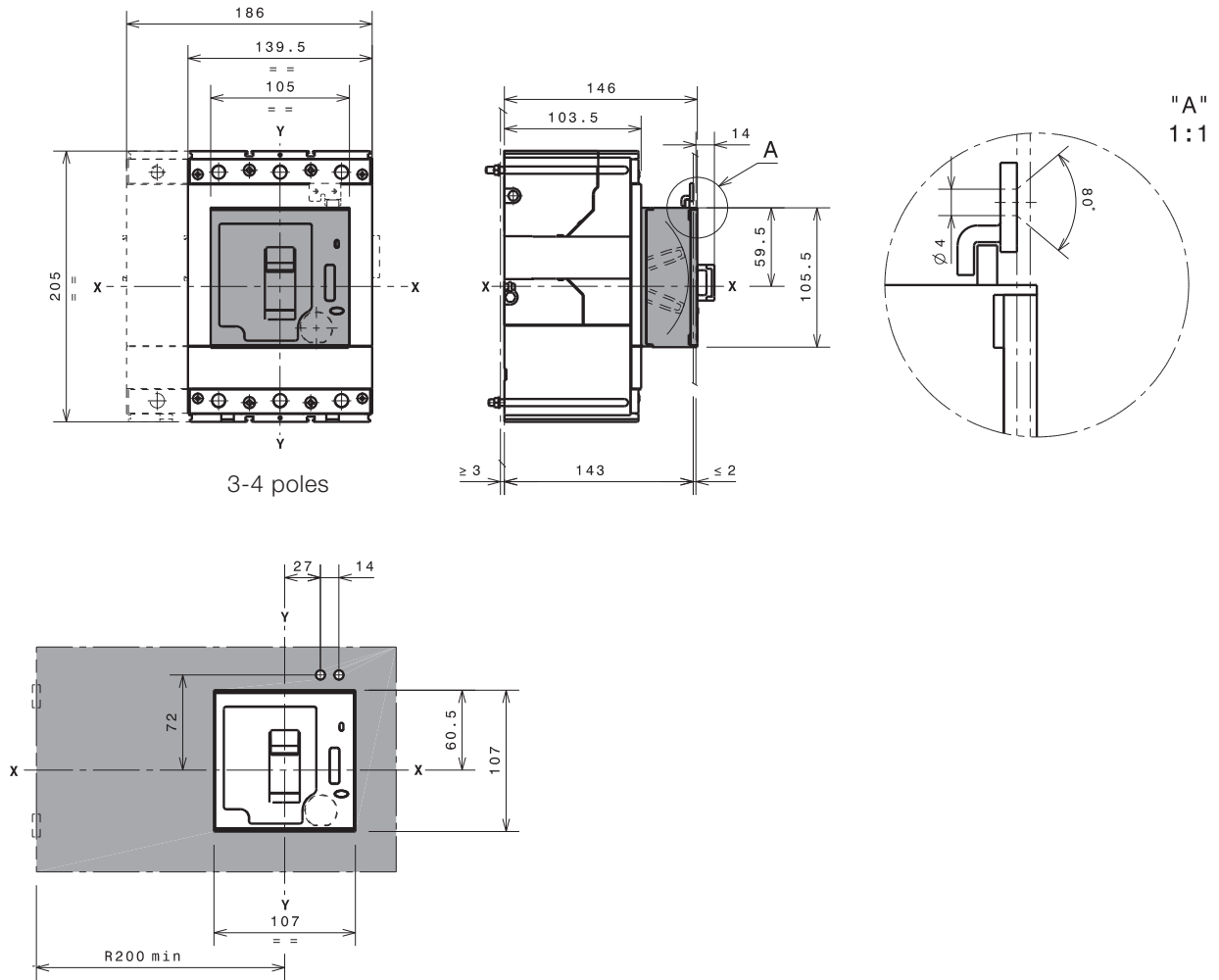

Overall dimensions

FORMULA Link 250A

FORMULA Link A1 250A

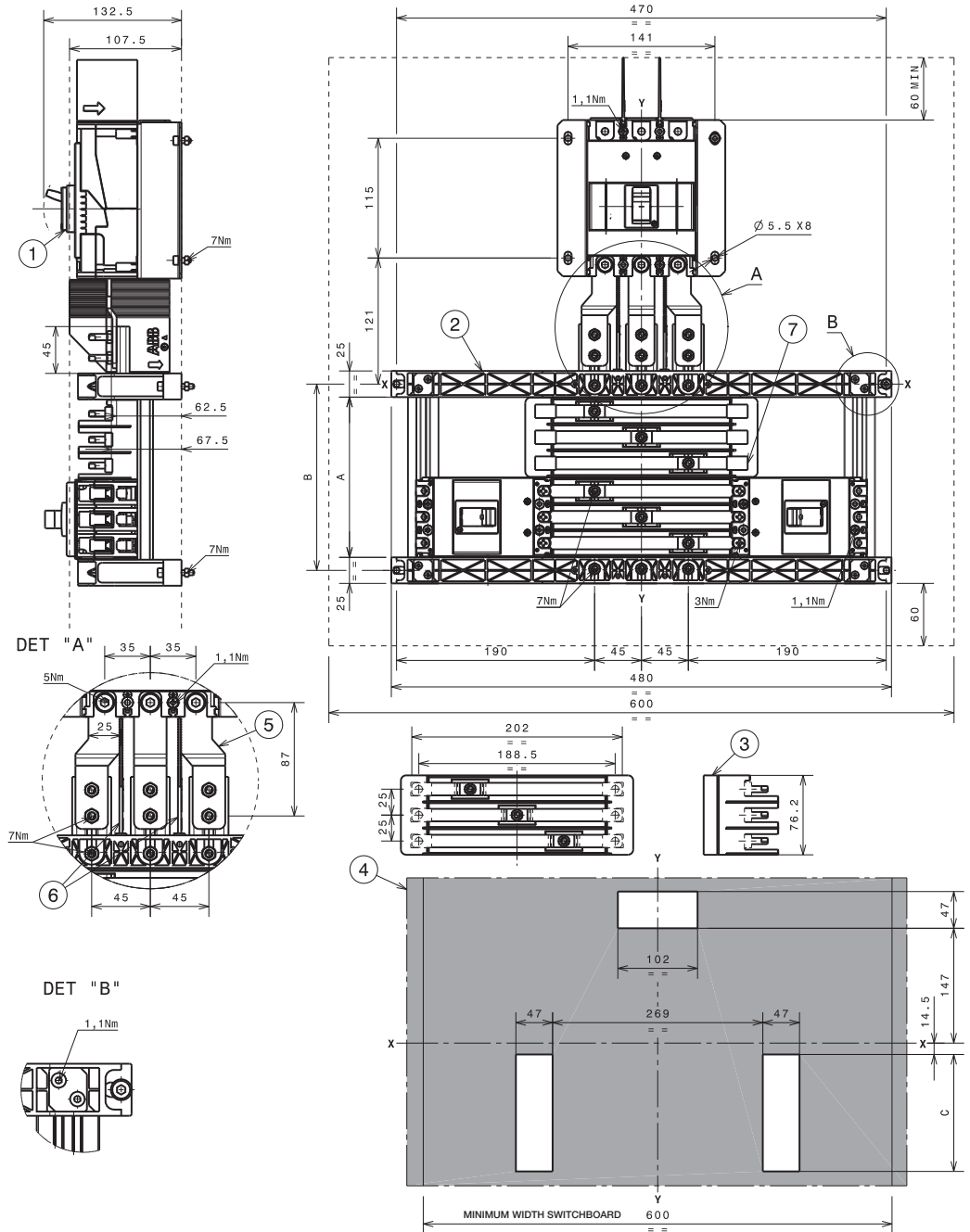

Caption

- ① Main SACE FORMULA A2 250 circuit-breaker
- ② Busbar holder for SACE FORMULA A1
- ③ Outgoing kit connection for SACE FORMULA A1
- ④ Compartment door drilling*
- ⑤ Incoming kit connection
- ⑥ Phase separators (compulsory) supplied
- ⑦ Stopper cover busbar (compulsory without insert circuit-breaker)

* considering all the outgoing circuit-breakers installed

Frame 250A	A [mm]	B [mm]	C [mm]
F1	154	179	150
F2	230.5	255.5	226.5
F3	307.5	332.5	303
F4	384	409	380
F5	461	486	456.5

Overall dimensions

Distances to be respected

Insulation distances to be respected for installation in cubicles

$U_e < 415V$	A [mm]	B [mm]	C [mm]
A1	45	20	35
A2	60	25	60
A3	30	25	25

$U_e \geq 440V$	A [mm]	B [mm]	C [mm]
A1	45	20	35
A2	180	25	60
A3	60	25	25

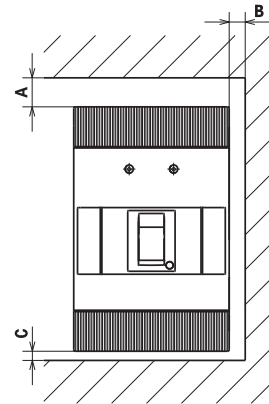

Minimum centre distance between two circuit-breakers side by side

	Circuit-breaker width [mm]				Centre distance I [mm]			
	1 pole	2 poles	3 poles	4 poles	1 pole	2 poles	3 poles	4 poles
A1	25.4	50.8	76.2	101.2	25.4*	50.8*	76.2*	101.2*
A2	36	70	105	140	36*	70*	105*	140*
A3	-	-	140	184	-	-	140**	184**

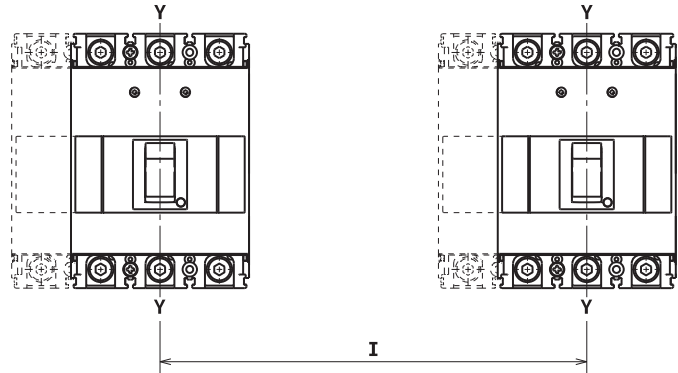

* For $440V \leq U_e \leq 550V$ | $3p=180mm$ and $4p=224mm$
 ** With separator to be requested apart and to be inserted between two circuit-breakers side by side.

Minimum centre distance between two stacked circuit-breakers

	H [mm]
A1	80
A2	100 ($U_e < 415V$) 260 ($U_e \geq 415V$)
A3	160

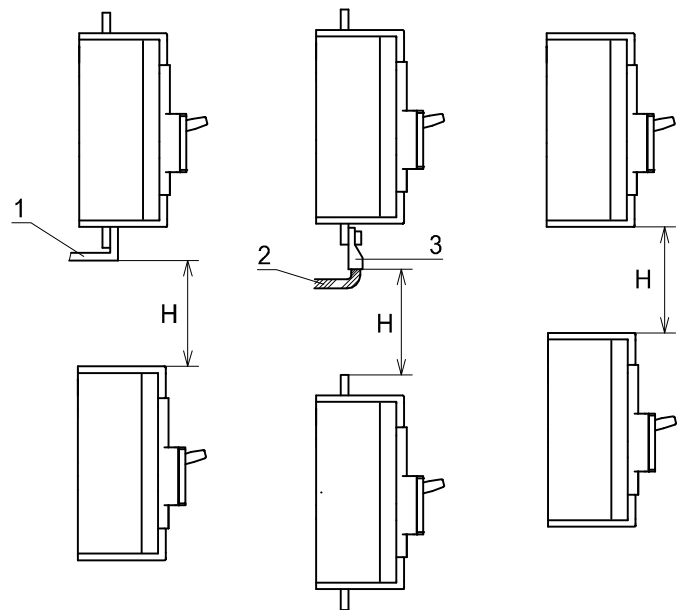

Caption

- ① Connection not insulated
- ② Insulated cable
- ③ Cable terminal



Content

G1 - Circuit-breaker	7/2
G2 - Performance Parameters	7/4
G3 - Releases and Protections	7/6
G4 - Regulations and Standards	7/7

Glossary

G1 - Circuit-breaker

G1.1 Circuit-breaker

A mechanical switching device, capable of making, carrying and breaking currents under normal circuit conditions and also making, carrying for a specified time and breaking currents under specified abnormal circuit conditions such as short-circuit.

G1.2 Protection degree (IP)

The IP protection degree indicates the level of protection for apparatus against contact with live parts and penetration of liquids and solid foreign bodies.

G1.3 Rate of contact wear

Percentage of contacts wear, indicatively gives the state of durability of the circuit-breaker contacts.

G1.4 Double insulation

A double insulation between the live power parts and the front parts of the apparatus where the operator works during normal plant service is present in all the circuit-breakers, so as to eliminate the risk of contacts with live parts. The seat of each electrical accessory is completely segregated from the power circuit. In particular, the operating unit is completely insulated in relation to the voltage circuits. Furthermore, both between the internal live parts and in the area of the connection terminals, the circuit-breaker has redundant insulation. In fact, the distances between the connection terminals are greater than those required by the IEC Standards and conform to what is prescribed by the American UL 489 Standard.

G1.5 Positive operation

The operating lever always indicates the actual position of the mobile circuit-breaker contacts:

- red line (I): Closed position;
- green line (O): Open position;
- yellow-green line: Trip Position, open due to release trip or test pushbutton.

The indications are precise and reliable, in conformity with what is prescribed by the IEC 60073 and IEC 60417-2 Standards.

Tripping of the releases automatically opens the mobile contacts and makes the lever move into the Trip position: to reclose the circuit-breaker it must be reset, by pushing the operating lever from the trip position to the Open position.

The operating mechanism of the circuit-breaker has free trip, independent of the pressure on the lever and of the speed of the operation.

From this position it is possible to close the circuit-breaker.

G1.6 Isolation behaviour

Characteristic of a mechanical operating device which, in the open and trip position, carries out a disconnection function and guarantees an insulation distance (distance between fixed and mobile contacts) sufficient to guarantee safety.

G1.7 Electromagnetic compatibility

In conformity with the IEC 60947-2 Standards (Annex B + Annex F, European Directive No. 89/336) relative to electromagnetic compatibility EMC, the circuit-breakers used with electronic trip units and residual current releases are guaranteed to function in the presence of disturbances caused by:

- electromagnetic apparatus;
- atmospheric disturbances which flow through power networks;
- interferences from radio waves;
- discharges of electrical type.

Furthermore, the circuit-breakers does not generate disturbances to other electronic apparatus near the place of installation.

G1.8 Tropicalization

All the circuit-breakers can be used in the most severe environmental conditions defined by the following standards:

- IEC 60721-2-1 (climograph 8);
- IEC 60068-2-30;
- IEC 60068-2-2;
- IEC 60068-2-52.

Tropicalization is guaranteed by:

- synthetic resin insulating boxes reinforced with fibreglass;
- anti-corrosion treatment of the main metallic parts;
- galvanisation Fe/Zn (UNI ISO 2081), protected by a conversion layer without hexavalent chromium (in conformity with the ROHS) with the same corrosion resistance guaranteed by ISO 4520 class 2c;
- application of anti-condensation protection for electronic overcurrent releases and relative accessories.

Glossary

G2 - Performance Parameters

G2.1 Frame size

A term designating a group of circuit-breakers, the external physical dimensions of which are common to a range of current ratings (considering the same number of poles). Frame size is expressed in amperes corresponding to the highest current rating of the group.

G2.2 Rated current (I_n)

For the circuit-breakers the rated current represent the current which the circuit-breaker can carry in uninterrupted duty.

G2.3 Rated service voltage (U_e)

The a rated service voltage of an equipment is the voltage value which, together with the rated service current, determines the use of the equipment and which the applicable tests and the utilization category refer to.

G2.4 Rated insulation voltage (U_i)

The rated insulation voltage of an equipment is the value of voltage to which dielectric tests and the surface creepage distances are referred. In no case the maximum value of the rated operating voltage shall exceed that of the rated insulation voltage.

G2.5 Rated impulse withstand voltage (U_{imp})

The peak value of an impulse voltage of prescribed form and polarity which the equipment is capable of withstanding without failure under specified test conditions and to which the clearance values are referred.

G2.6 Rated ultimate short-circuit breaking capacity (I_{cu})

The rated ultimate short-circuit breaking capacity of a circuit-breaker is the maximum short-circuit current value which the circuit-breaker can break twice (in accordance with the cycle O - t - CO), at the corresponding rated operational voltage. After the indicated sequence the circuit-breaker is not required to carry its rated current.

G2.7 Rated service short-circuit breaking capacity (I_{cs})

The rated service short-circuit breaking capacity of a circuit-breaker is the maximum short-circuit current value which the circuit-breaker can break three times in accordance with a sequence of opening, pause and closing operations (O - t - CO - t - CO) at a defined rated service voltage (U_e) and at a defined power factor. After the indicated sequence the circuit-breaker is required to carry its rated current.

G2.8 Rated short-circuit making capacity (I_{cm}):

The rated short-circuit making capacity of an equipment is the value, stated by the manufacturer, at the rated service voltage, at rated frequency, and at a specified power factor for alternating current or time constant direct current. It is expressed as the maximum peak value of the prospective current under specified conditions.

G2.9 Utilization category of circuit-breakers

The utilization category of a circuit-breaker must be established according to whether or not it is specifically intended for selectivity by means of an intentional time delay, with respect to other circuit-breaker in series on the load side, under short-circuit conditions. Two category of use can be specified:

Category A - Circuit-breakers not specifically intended for selectivity under short-circuit conditions with respect to other short-circuit protective devices in series on the load side, i.e. without a short-time withstand current rating.

Category B - Circuit-breakers specifically intended for selectivity under short-circuit conditions with respect to other protection devices in series on the load side, i.e. with intentional time delay (which can be adjustable) applicable under short-circuit conditions. These circuit-breakers have specified short-time withstand current rating (I_{cw}).

A circuit-breaker is classified in category B if its I_{cw} value is higher than:

- between $12 \times I_n$ and 5kA, whichever is the greatest, for $I_n \leq 2500A$;
- 30 kA, for $I_n > 2500A$.

G2.10 Mechanical life

The mechanical durability (or mechanical life) of an apparatus is expressed by the number of no-load operating cycles (each operating cycle consists of one closing and opening operation) which can be carried out by the apparatus before it becomes necessary to service or replace any of its mechanical parts (however, normal maintenance is permitted).

G2.11 Electrical life

Electrical durability (or electrical life) of an apparatus is expressed by the number of on-load operating cycles and the resistance of the contacts to electrical wear under the conditions specified in the relevant Product Standard.

G2.12 Dissipated power

Is the energy loss caused by the Joule effect due to the electrical resistance of the circuit-breaker poles. The energy lost is dissipated in the form of heat.

G2.13 Utilization categories of the auxiliary contacts

The utilization categories given in the table are considered standardised. [CEI EN 60947-5-1]

Kind of current	Category	Typical application
Alternating current	AC-12	Control of resistive loads and solid state loads with isolation by optocouplers
	AC-13	Control of solid state loads with transformer isolation
	AC-14	Control of small electromagnetic loads ($\leq 72VA$)
	AC-15	Control of electromagnetic loads ($> 72VA$)
Direct current	DC-12	Control of resistive loads and solid state loads with isolation by optocouplers
	DC-13	Control of electromagnets
	DC-14	Control of small electromagnetic loads having economy resistors in circuit

Glossary

G3 - Releases and Protections

G3.1 Trip unit

Device, mechanically connected to a mechanical operating mechanism, which release the latching parts and allows the opening or closing of the operating device.

G3.2 Thermomagnetic trip unit

Thermomagnetic trip units use a bimetal and an electromagnet to detect overloads and short-circuits. They are suitable for protection of both alternating and direct current networks.

G3.3 Electronic trip unit

Trip units connected to current transformers (three or four according to the number of conductors to be protected) positioned inside the circuit-breaker, which carry out the double function of supplying the power supply needed for correct operation of the release (self-supply) and of detecting the value of the current which flows through the live conductors. However, they are only compatible with alternating current networks. The signal coming from the transformers and from the Rogowsky coils is appropriately processed by the electronics (microprocessor) which compares it with the set thresholds. When the signal exceeds the thresholds, the trip of the circuit-breaker is operated through an opening solenoid which acts directly on the circuit-breaker operating mechanism unit.

In the case of an auxiliary power supply in addition to self-supply, the voltage must have a value of 24V DC \pm 20%.

G3.4 Thermal Protection L

Protection against overloads with long inverse time delay trip.

G3.5 Magnetic Protection I

Protection against short-circuit with instantaneous trip.

Glossary

G4 - Regulations and Standards

G4.1 Standards

Technical specification approved by a recognised organisation with the task of defining the state-of-the-art characteristics (dimensional, environmental, safety, etc.) of a product or service.

G4.2 Directive

Ensemble of rules which define the essential requirements regarding safety which the products must comply with in order to guarantee user safety.

G4.3 RoHS Directive

European Directive 2002/95/EC of 27 January 2003 (Dlgs 25 July 2005 no. 151) which aims at eliminating or reducing the use of hazardous substances in electrical and electronic apparatus.

It imposes manufacturers and companies to adapt to the relative prescriptions drawing up a manufacturer's declaration, without third party certification.

Contact us

ABB SACE

A division of ABB S.p.A.

L.V. Breakers

Via Baioni, 35

24123 Bergamo

Phone: +39 035 395.111

Fax: +39 035 395.306-433

www.abb.com

The data and illustrations are not binding. We reserve the right to modify the contents of this document on the basis of technical development of the products, without prior notice.

Copyright 2011 ABB.
All rights reserved.

1SDC210082D0204 - 03.2011 - 2.000